



LS ROUTER MANUAL

T:0116 2769111

F:0116 2598138

W: www.wadkingburgsgreen.co.uk

Wadkin

HIGH SPEED ROUTER TYPE L. S. PRINCIPAL DIMENSIONS AND CAPACITIES :-

Centre of cutter spindle to inside of body frame		24½"
Maximum distance between table and chuck: Standard table		9"
Compound table		8½"
Chuck will take cutter shanks up to 9/16" diameter.		
Total travel of cutter spindle		4"
Size of standard table		30" x 30"
Raising and lowering movement of table		5"
Minimum height of table from floor: Standard table		2'11"
Compound table		3'0"
Size of table with compound movements		27" x 33"
Longitudinal movement		30"
Transverse movement		15¼"
Cutter spindle speeds in r. p. m. : For 50 cycles	18,000 and 24,000	
For 60 cycles,	18,000 and 25,000	
Floor space		5'6" x 2'6"
Horse power of motor: Continuous rating		2
Intermittent rating		8½
	Standard Table	Compound Table
Net weight in cwts. with plain table, including frequency changer	15 (1680 lbs.)	19 (2128 lbs.)
Gross weight in cwts. with plain table, including frequency changer ..	19 (2128 lbs.)	23 (2576 lbs.)
Shipping dimensions in cubic feet	97	90
Code Words (add particulars of electric supply)		
With standard table	Labas	-
With compound table	-	Lupos
Details included with the machines	One each collets for ¼", 3/8", ½" and 9/16" cutter shanks.	
Motor, control gear, frequency changer.	Removable ring for table. One set of spanners.	
One each parallel guide pins, 3/16" x ¼", 5/16" x 3/8", 7/16" x ½".	Safety cutter guard.	
One each 5/16" x 7/16" taper and 3/16" taper x 5/8" parallel guide pins.	Supply of our special ball bearing lubricant and high speed oil.	
One each 5/8" and ¾" guide rollers.	One grease gun.	
	One oil gun.	

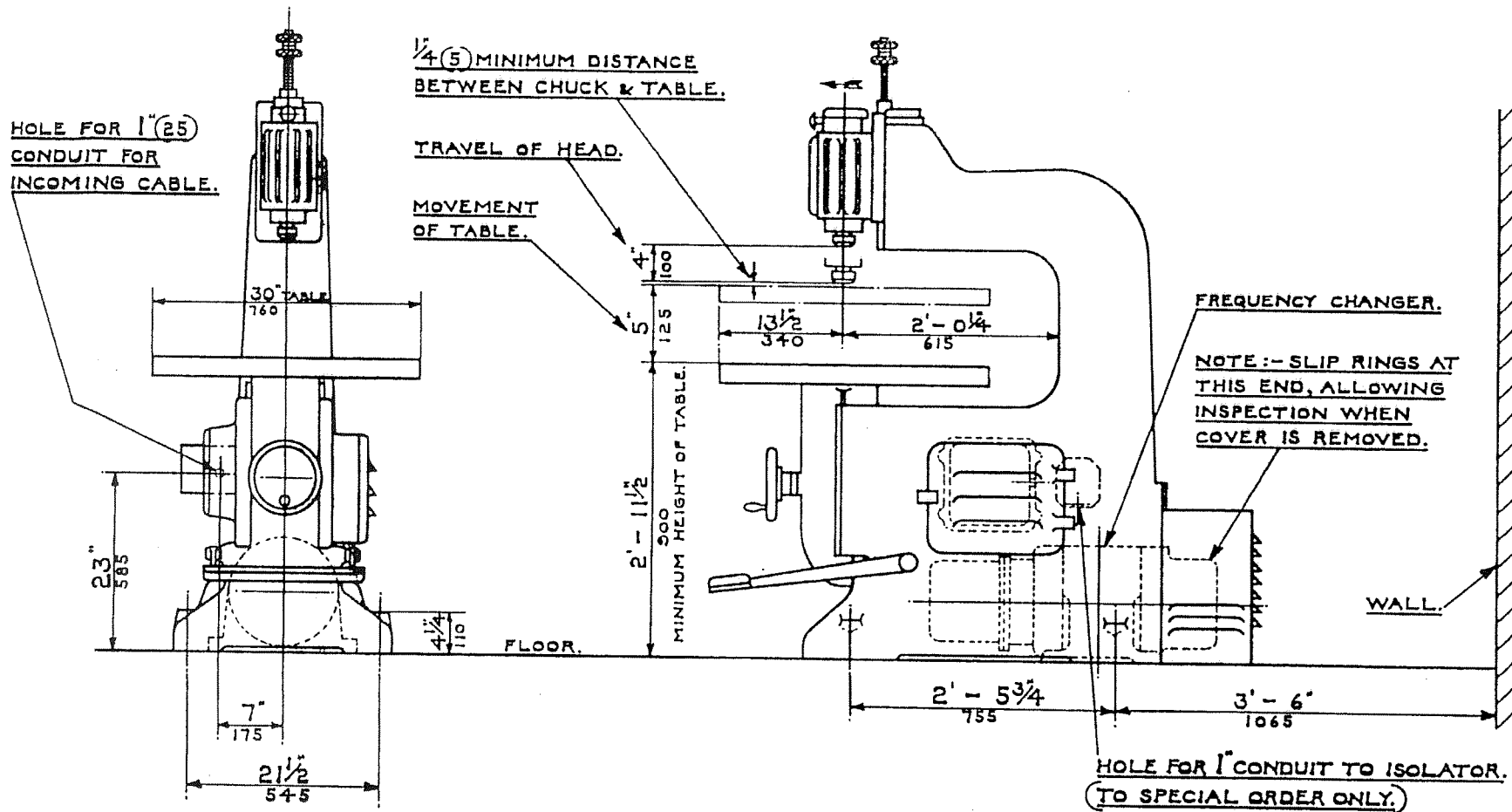

HIGH SPEED ROUTER. TYPE LS.

SCALE 1" TO 1 FOOT.

DIMENSIONS IN FEET AND MILLIMETRES.

INSTALLATION

The machine is despatched from the Works with all bright surfaces greased to prevent rusting. This must be removed by applying a cloth damped with paraffin or turpentine.

FOUNDATIONS.

Four 5/8" diameter foundation bolts must be used to bolt machine down to the floor. Foundation bolts are not supplied by Wadkin Ltd. unless specially ordered. "Rag" type holding down bolts may be used. If mill floor consists of from 4" to 6" solid concrete no special foundation is necessary. Cut out in concrete 4" to 6" square holes and fill in and grout with liquid cement after machine has been carefully levelled.

ELECTRICAL CONNECTIONS

See Page 65 for details and connection diagram.

IMPORTANT :- The frequency changer must NOT be bolted down but placed inside the main frame after the machine is finally fixed. Make sure that the surface is level and smooth to enable the frequency changer to be readily withdrawn

Alignment of Table Pin to Spindle. A Setting Arbor is supplied for checking this alignment. The table is not dowelled to the vertical slide, so that it can be reset from time to time with the head.

Fit the setting arbor in the spindle and lower head to table. Now slacken 4 screws securing table to vertical slide and float table horizontally until the arbor in spindle enters pin hole in table. Relevel table securing screws, and remove arbor from spindle.

LUBRICATION CHART

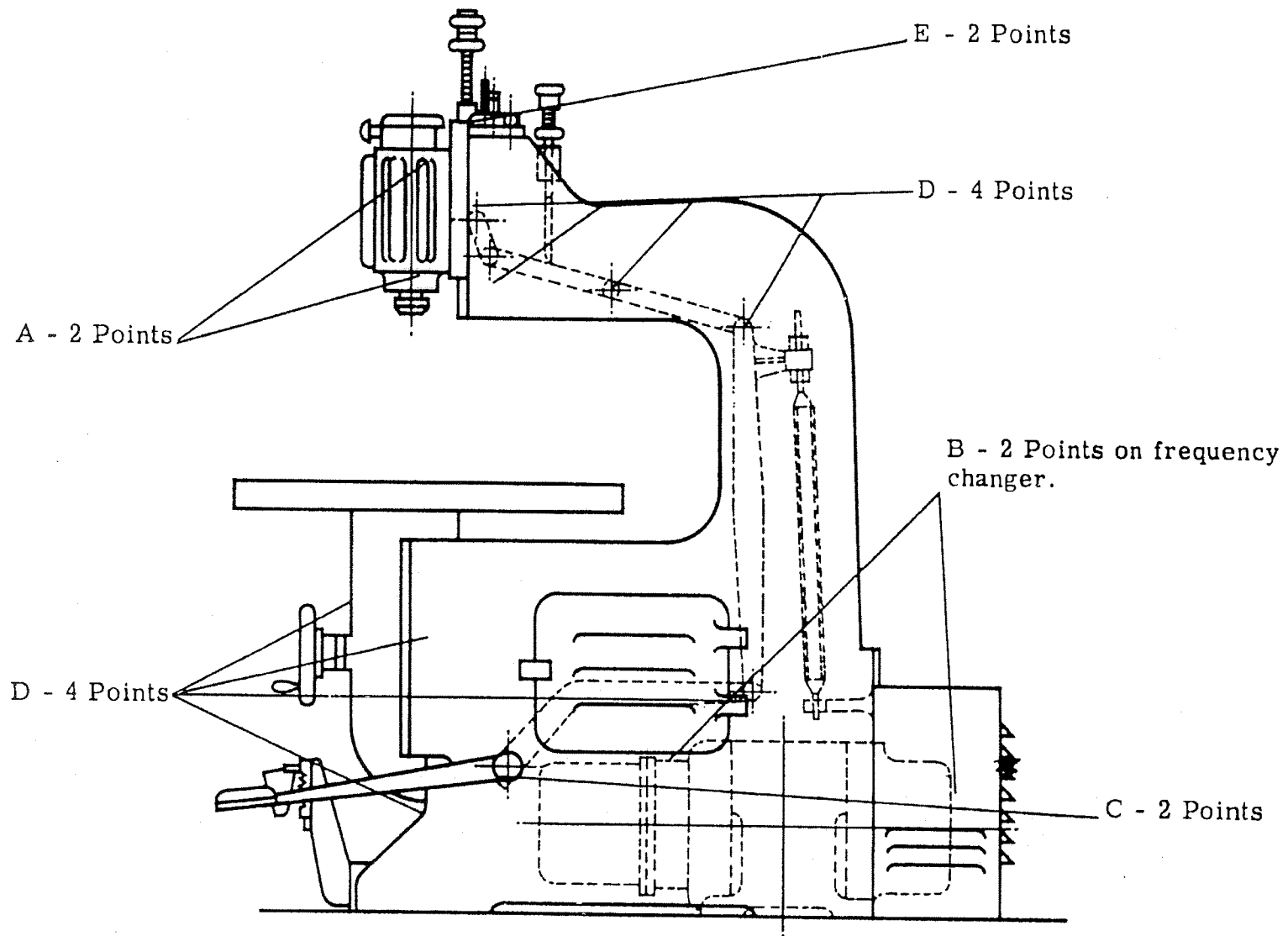

LUBRICATION

POINTS "A" - Ball bearings. Give one charge or depression of the oil gun to each bearing of L. 1 oil once daily (cutterhead), or 2 to 3 shots if machine has been standing idle for longer than 48 hours.

POINTS "B" - Ball bearings. Give one to two charges or depressions of the grease gun every three months.

POINTS "C" - Roller bearings. Give one charge or depression of grease gun every three months.

POINTS "D" - Give one charge or depression of grease gun weekly.

POINTS "E" - Fill oil reservoirs twice weekly with oil L. 4.

It is most important that these lubricating instructions be strictly adhered to in order to obtain full efficiency from the machine. On cutterhead spindle bearing, Points "A", use only Wadkin special oil Grade L. 1 or equivalent. (See below). At Points "B", "C" and "D" use only Wadkin special high speed ball bearing grease Grade L. 6 or equivalent. (See below). The machine should be cleaned down weekly.

EQUIVALENT LUBRICANTS			
Wadkin Grade and Type	Mobil	Shell	B. P.
Oil Grade L. 1	D. T. E. Oil Light	Tellus 27	Energol HL 65
Oil Grade L. 4	Vacra Oil Heavy Medium	Tellus 33	Energol HL 100
Grease Grade L. 6	Mobil Plex 48	Shell Alvania R3	Energol LS. 3

Maker's No.	Size Bore x O/D x Width	Number Per Machine	Where used on Machine
Hoffmann N3420)) Made specially for) Wadkin Ltd.	25 mm x 52 mm x 15 mm	1	Router head top
Hoffmann N3243)) Replacements should) be obtained from) Wadkin.	30 mm x 62 mm x 16 mm	1	Router head bottom
Hoffmann MS. 10 (Ball)	1" x 2 $\frac{1}{2}$ " x $\frac{3}{4}$ "	1	Frequency changer, driving end
Hoffmann MS. 12 (Ball)	1 $\frac{1}{4}$ " x 3 $\frac{1}{8}$ " x $\frac{7}{8}$ "	1	Frequency changer, non driving end

HIGH SPEED ROUTER MODEL L.S. - THE HEAD - TYPE Q

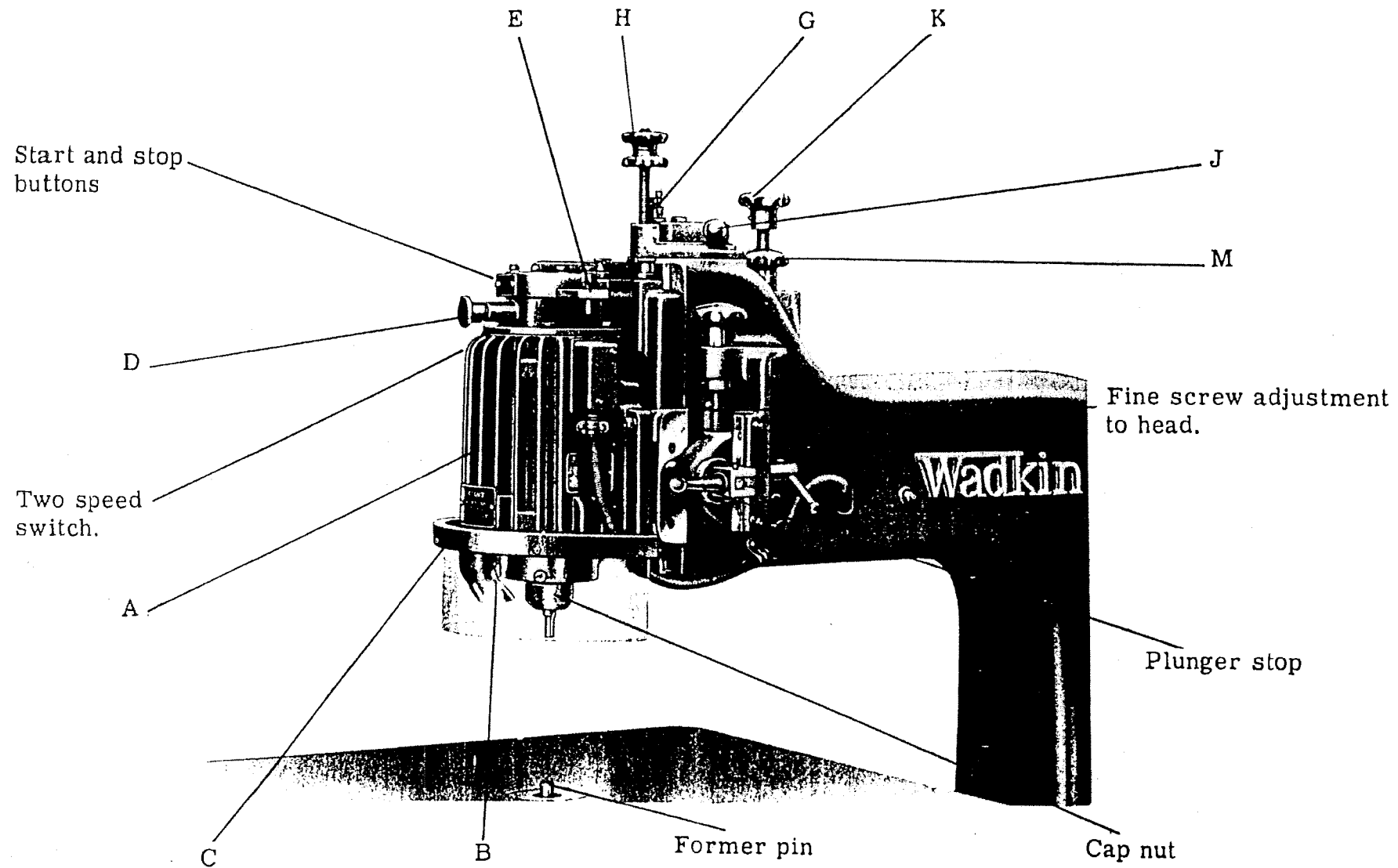

Fig. 1

THE HEAD.

The cutterhead motor, Fig. 1, is built directly onto a nickel chrome steel spindle which runs on precision high speed bearings. Blower "B" is incorporated in the head to dislodge chips from the face of the work. Transparent guard "C", which can be swung away for easy access to the cutter, gives full protection to the operator without obstructing his view of the job. A quick acting brake and also a spindle lock for use when cutter changing are incorporated. The brake is operated by pressing the knob "D" after the motor has been switched off. The lock is operated by sliding the locking bar, "E", INWARDS to lock the spindle and OUT to unlock. Care should be taken not to start the machine whilst the locking bar is in position.

MOVEMENT OF THE HEAD.

The head is brought down and locked by means of the foot treadle (see Fig. II). A touch on the auxiliary toe pedal disengages the ratchet holding the head which is counterbalanced so that it rises out of the work automatically. The travel of the head is limited by stops for movement both up and down. A range of four stops, "G", controls the downward movement. Any one of these stops may be selected by means of the hand lever "J". A long stop screw "H" gives a wide range of movement to the head. The upward movement of the head is controlled by an adjustable stop "K". To reduce the travel of the head the locking handwheel "M" is first loosened and the stop then screwed in a clockwise direction, the locking handwheel being tightened again afterwards. To increase the travel of the head the stop is screwed in an anti-clockwise direction.

HIGH SPEED ROUTER, MODEL L. S.

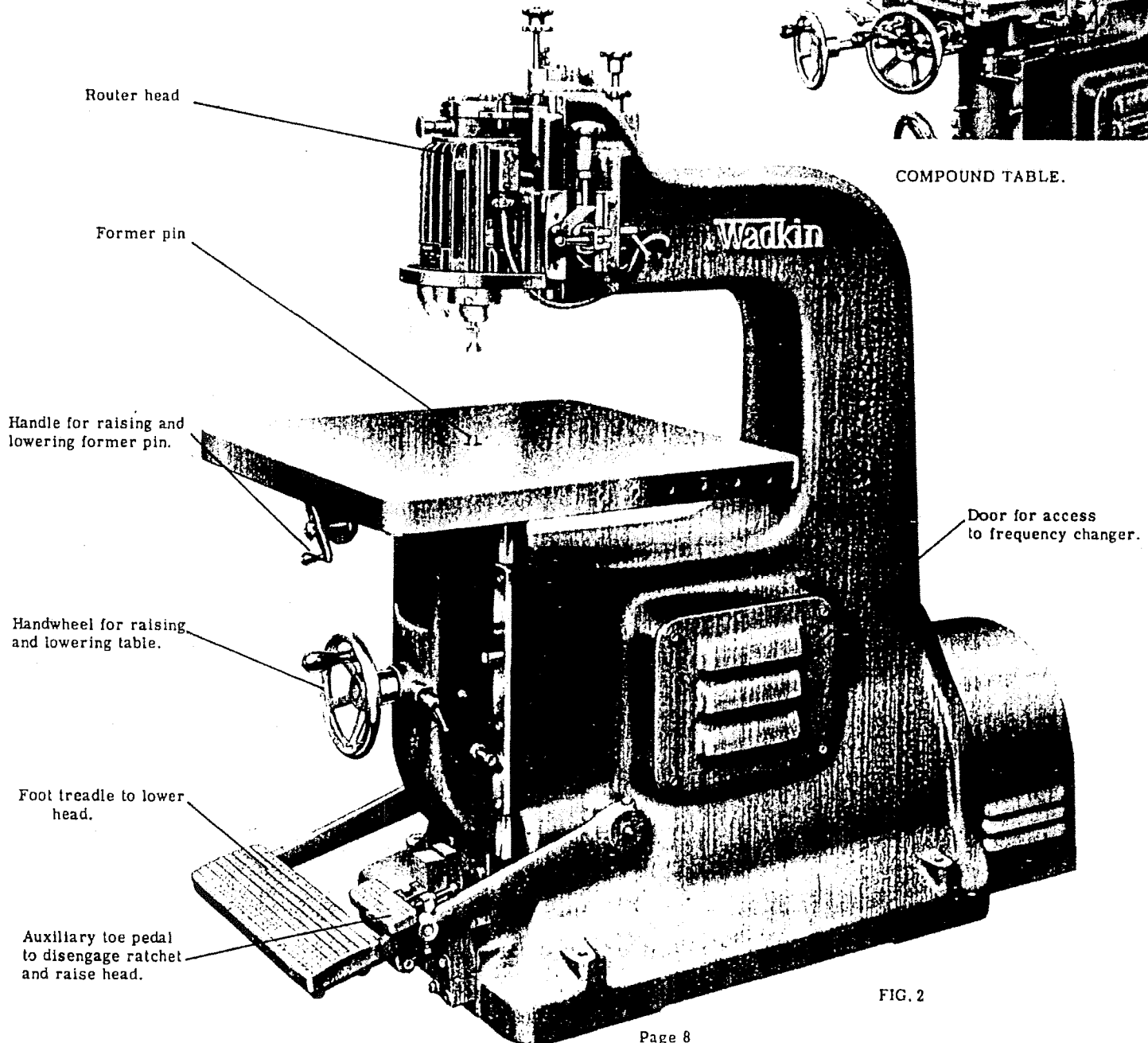

COMPOUND TABLE.

FIG. 2

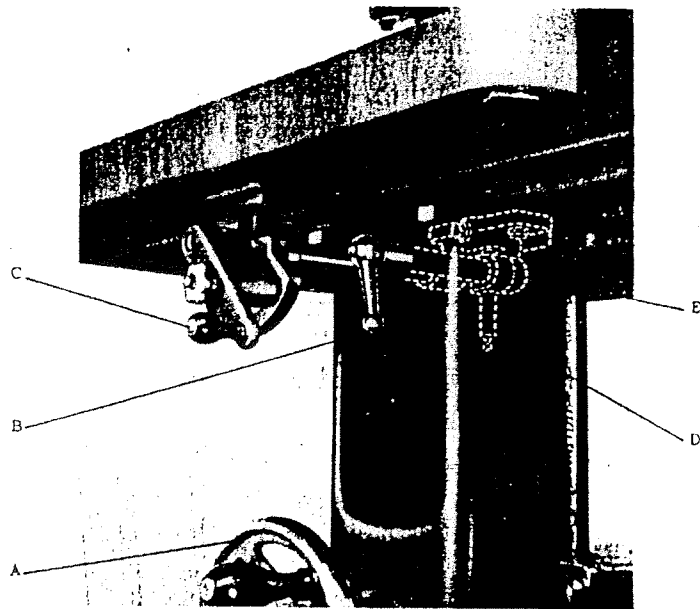

Fig. 4

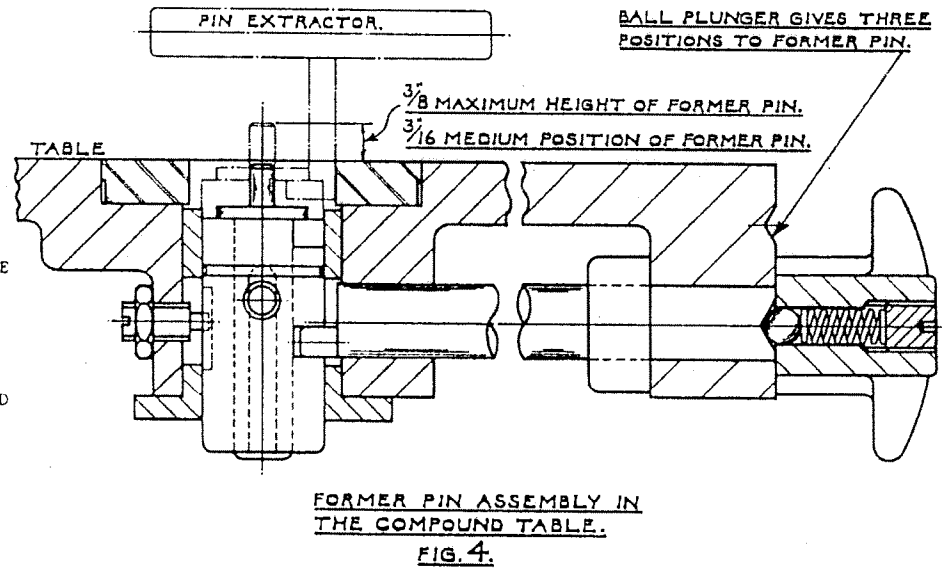

TABLE.

The table can be supplied in two forms, either a plain table as Fig. 2, or one with compound movements as illustrated opposite. For general routing operations using jigs with shaped formers or templates a plain table is recommended. When heavy cuts are required where it is necessary to clamp the work to the table for straight work, the compound table is ideal using the longitudinal and transverse movements.

It is not possible to change the tables after the machine is despatched.

Both tables have a removable centre plate to allow the cutter to work below the surface when moulding, etc. A series of holes in the tables are for securing fences, for straight cutting such as edge moulding.

FORMER OR GUIDE PIN.

The routing of all kinds of shaped work is done with jigs, the cutter reproducing the shape. A formed shape or template is attached to the underside of the jig and is worked round a pin projecting through the table as shown on page 14 and subsequent pages.

The pins are reversible in the plain table, each end being made a different size to correspond with the diameter of the cutter. The lever "C", Fig. 4 (see also page 12) gives three heights of the pin above the table to allow for different depths of cut or sinking. To change the pins, slacken handle "B" on holder "D".

The pins are not reversible in the compound table but are quickly detachable by the key provided and as shown in the illustration Fig. 4. The three positions of the pin are controlled by ball plunger.

The following former pins and rollers can be supplied :-

Pins for Plain Table	Pins for Compound Table	Rollers for both types of pin
$3/16'' - \frac{1}{4}''$) Double ended $5/16'' - \frac{3}{8}''$) and $7/16'' - \frac{1}{2}''$) Reversible	$3/16''$, $\frac{1}{4}''$, $5/16''$, $\frac{3}{8}''$, $\frac{1}{2}''$ These are single ended and not reversible.	$\frac{5}{8}''$, $\frac{3}{4}''$, $\frac{7}{8}''$, $1''$, $1\frac{1}{8}''$, $1\frac{1}{4}''$, $1\frac{3}{8}''$, $1\frac{1}{2}''$ All rollers are arranged to fit the $\frac{3}{8}''$ size pins only.

THE ROUTER HEAD is shown in section on page 11.

The bearings are lubricated by a patented system of oil mist lubrication and therefore it is important to use the oil and to lubricate the bearings to instructions given on page 5. Since the introduction of our patented system, the special high speed ball bearings (which must be purchased from Wadkin Ltd.) have given exceptional performance, but as no guarantee can be given against bearing failure which could be attributable to over lubrication or other causes, it is recommended that the Head is returned to us for repair.

We have a Service Department where the work is undertaken with the minimum delay.

Where machines are shipped abroad this service arrangement cannot economically be given. Under these circumstances a description of how to dismantle the Head is given on page 11.

A device to assist with the removal of the ROTOR is included with export machines.

LOOSE END PLUG INSERTED IN SPINDLE TO TAKE THRUST OF SCREW.



SCREW JACK FOR REMOVING ROTOR.

TO DISMANTLE SPINDLE CARRY OUT THE FOLLOWING IN THE ORDER NAMED :-

1. Remove cover "L" (see Fig. 6) and locking bar.
2. Detach nut "N" (left hand thread). Lift off brake drum housing "M" and brake drum "O".
3. Remove keys "Z".
4. Remove bottom cover "P" and collet.
5. Drive the spindle downwards by gentle blows from the top, when the complete spindle with rotor will emerge from the housing.
6. To remove the rotor use the screw jack provided as shown (Fig. 5) in order to avoid damage to the rotor and spindle.
7. **IMPORTANT:** Do not subject the rotor or bearings to hammer blows.
8. In removing lower bearing, take off sleeve "U", nut "T" (left hand thread) and fan.
9. Before reassembling spindle, thoroughly clean bearings and housings free of old lubricant and smear balls with a little new lubricant.
10. To reassemble spindle, first fix lower bearing, fan, nut "T", and sleeve "U". Afterwards press on the rotor and collar "V". The spindle is now passed through the lower end housing and up through the motor casing. The lower bearing must be carefully pressed into position by hand pressure, when the cover "P" is afterwards fixed. The oil seal "W", the bearing, sleeve "X" and brake housing "M" are now assembled

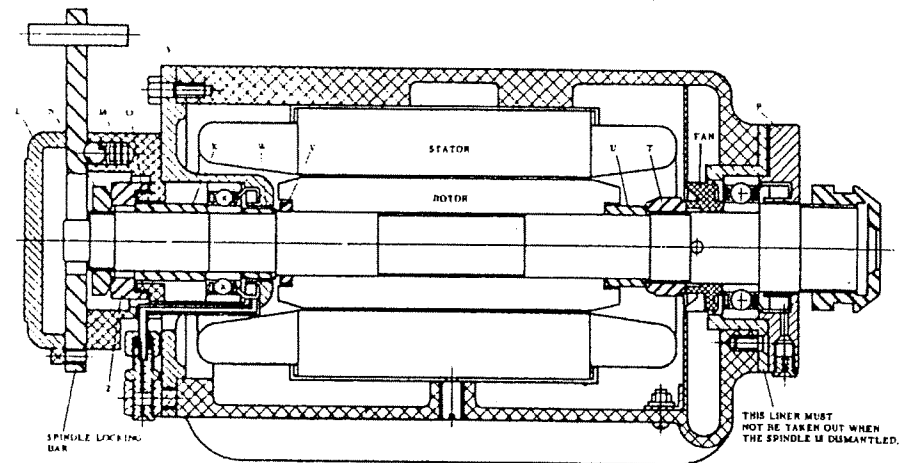

Q TYPE MOTOR HEAD ASSEMBLY FIG. 4

THE LUBRICATION OF THE BEARINGS ON THIS HEAD ARE COVERED BY PATENT NO. 491781.

Former pin in
low position.

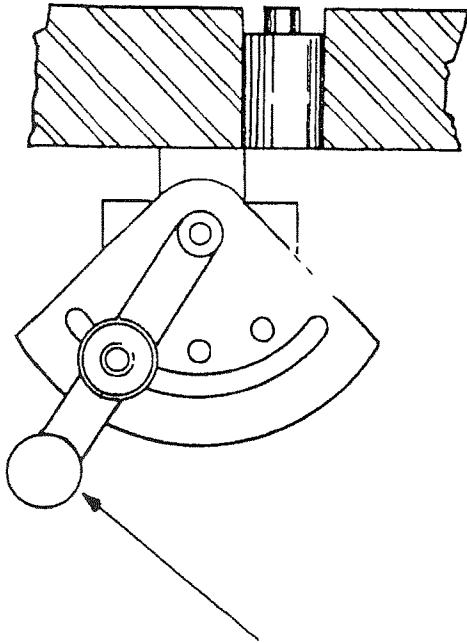

Former pin in
mid position.

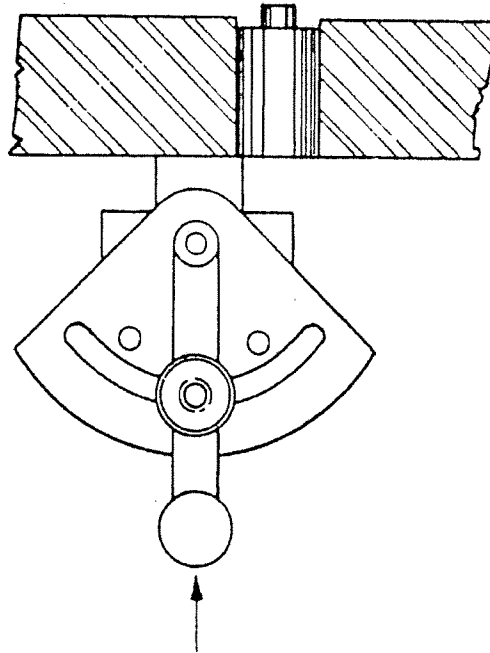

Former pin in
high position.

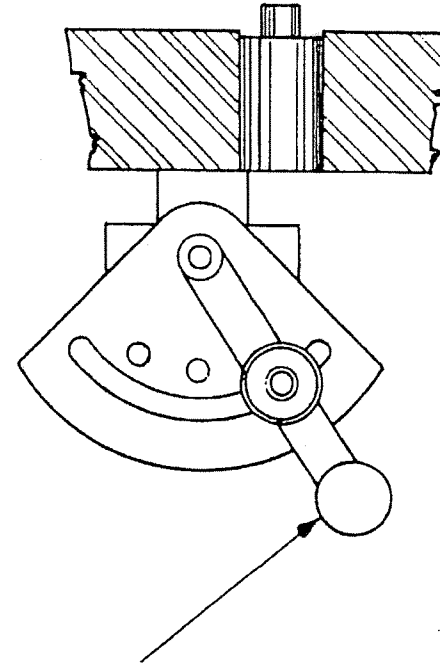

Lever handle for controlling rise and fall movement of former pin.

To allow for various thicknesses and position of templates on jigs also multiple templates, the former pin has three controlled positions.

THE BASIC PRINCIPLES OF ROUTING TO PROFILED SHAPES.

CUTTER

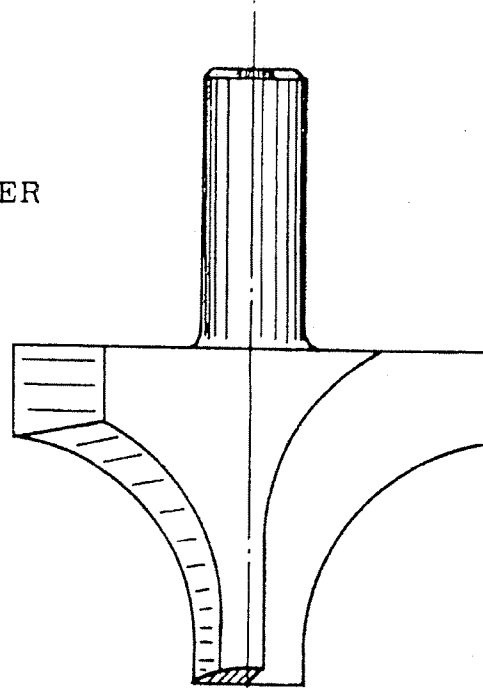

The smallest diameter of the router cutter and the diameter of the former pin should be the same.

FORMER PIN

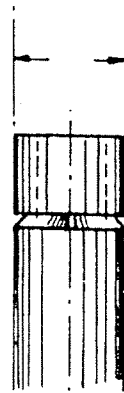

The component produced will then be correct in size and profile.

COMPONENT

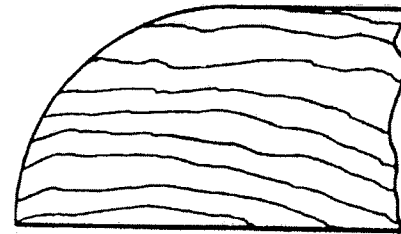

TEMPLATE

The template should be the same profile and size as the component or article to be produced.

ROUTER JIG FOR PROFILING

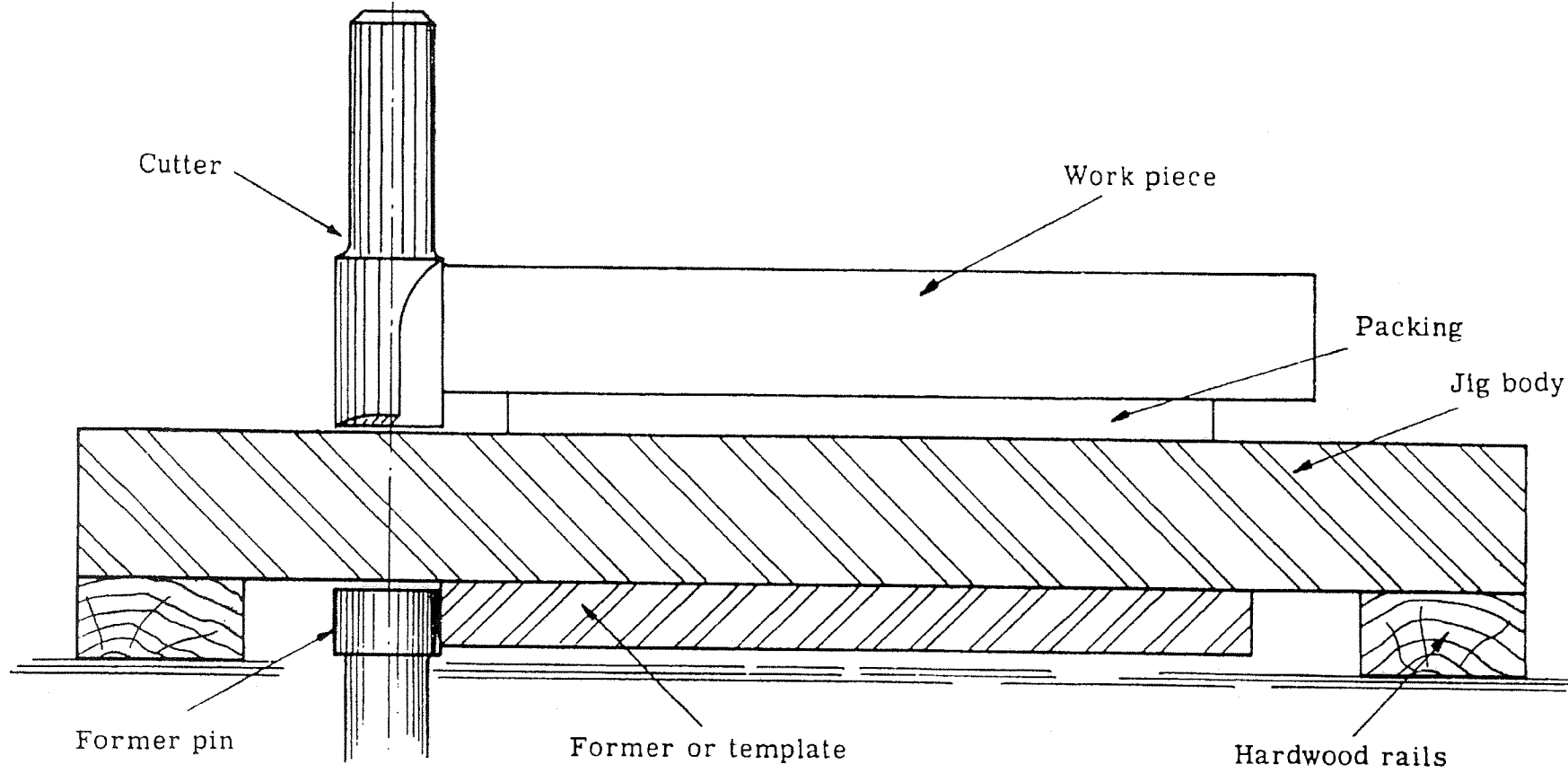

JIG FOR PROFILING

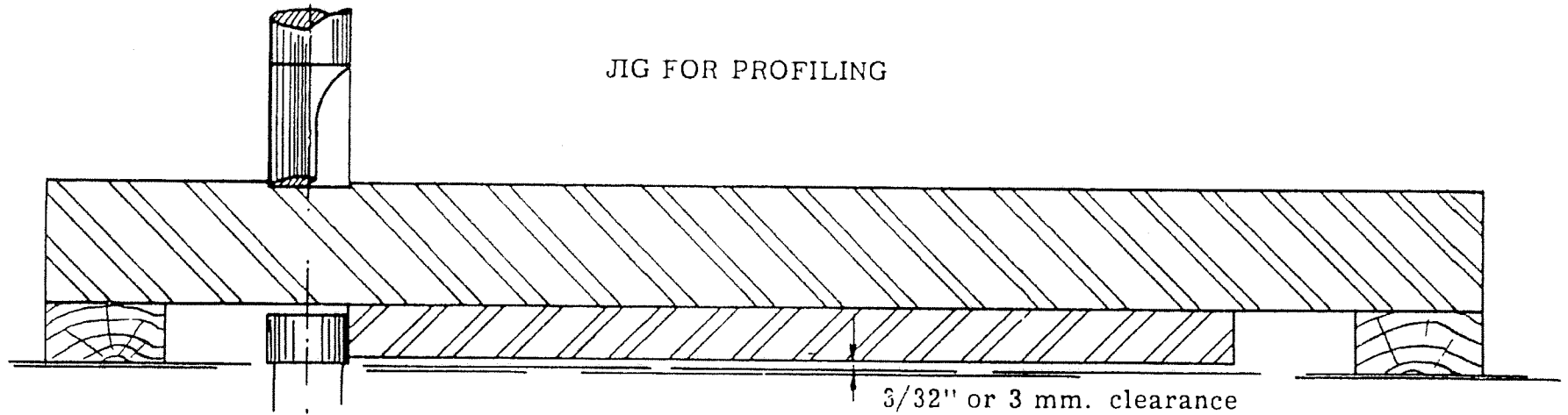

Fix hardwood rails to jig body and screw template in suitable position. It is advisable to have the jig 4" or 5" (100 mm. or 150 mm.) larger all round than the work piece. Fix rails and template, mark the surface of jig body by making a shallow cut with suitable size of cutter, tracing the shape of the template on the face of the jig. Cutter and former pin must be of same diameter.

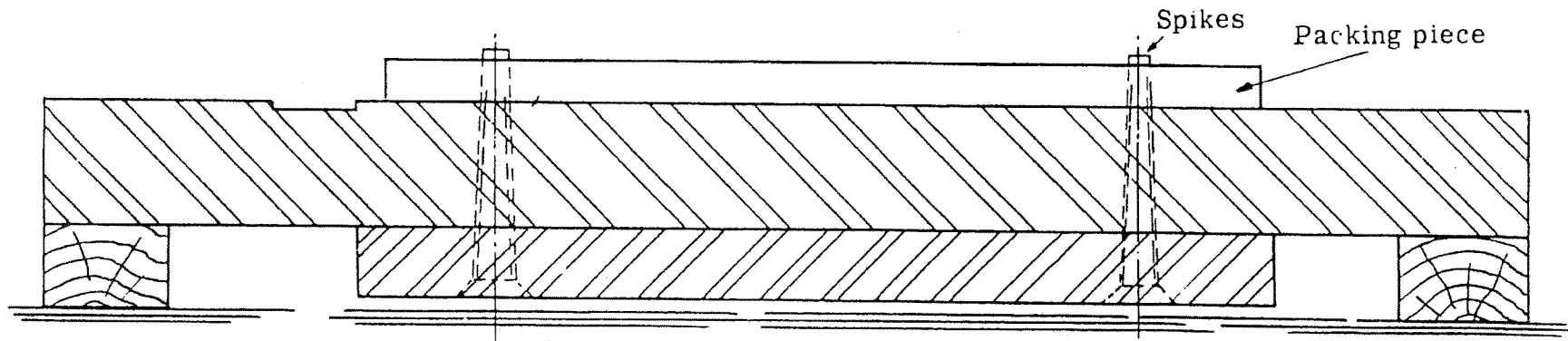

Having surface of jig correspondingly marked with the shape and position of template the packing piece can be fixed in position.

If holding spikes are required these can be fitted. Use wood screws of suitable length to project $3/32''$ (3 mm.) through packing piece. File screw ends to a chisel edge.

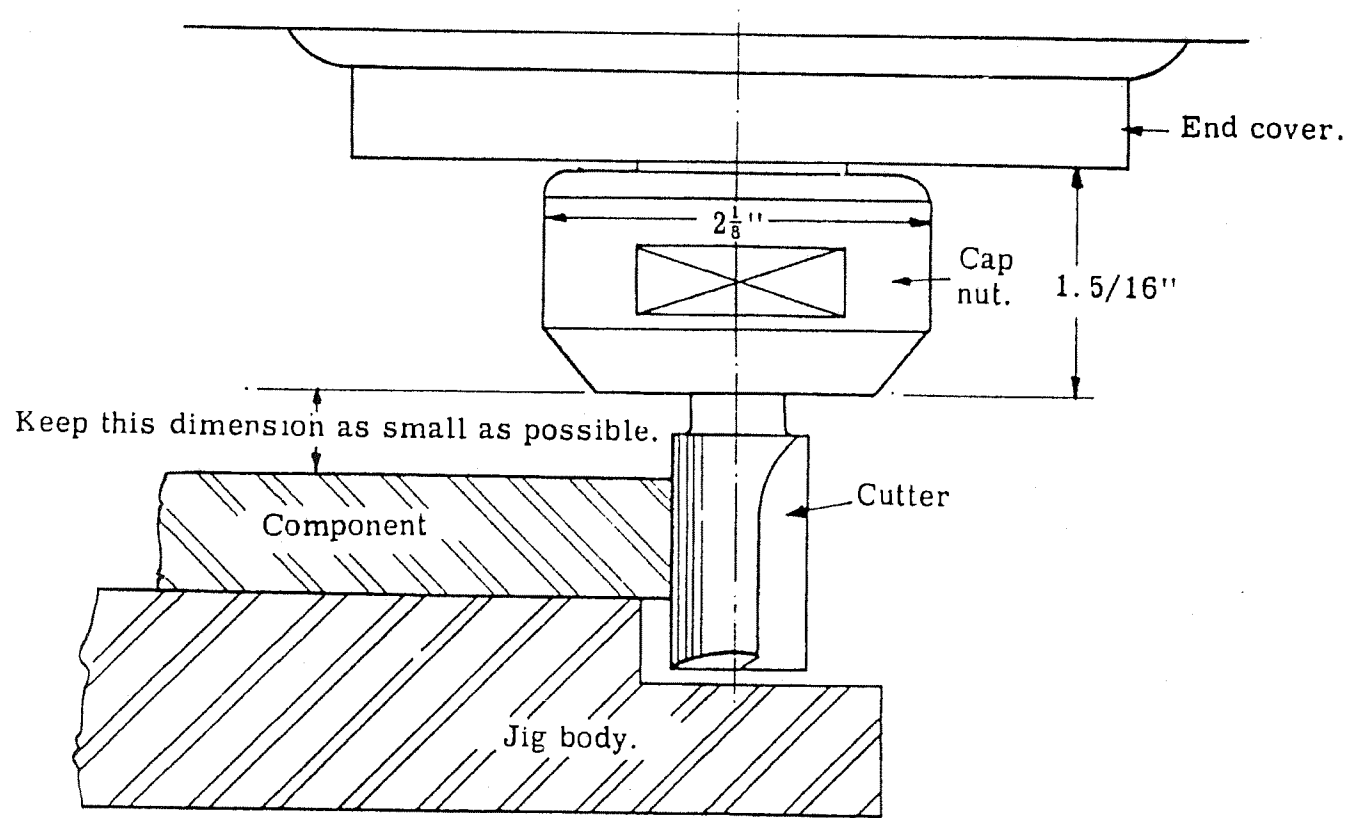

Always keep the top face of the component as near to the collet cap nut as possible.
 Any top cramping device must be low enough to clear the end cover of router head.

Jig for routing to shape curved components such as brush backs, etc.

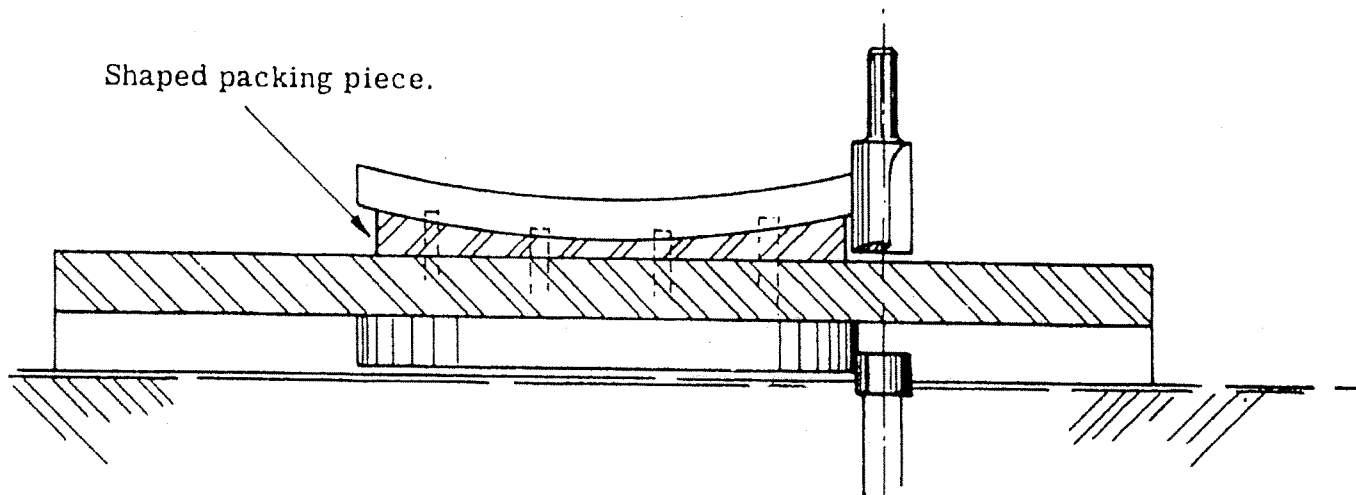
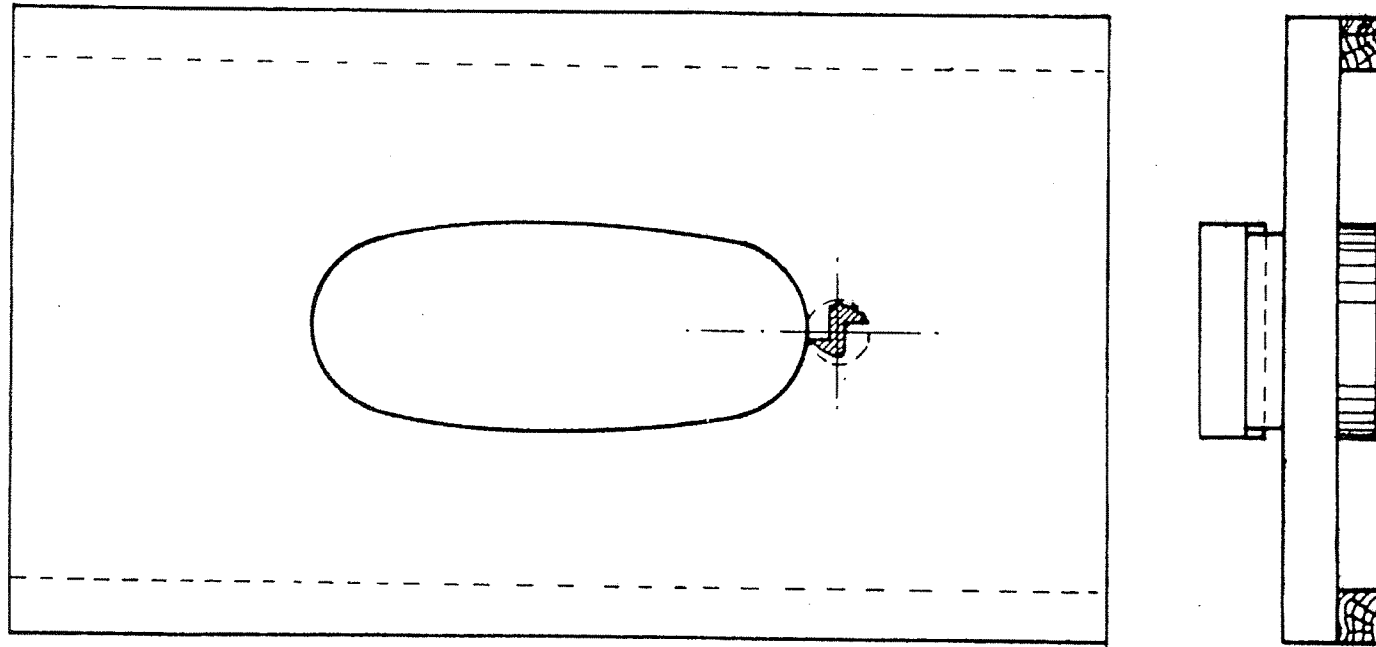

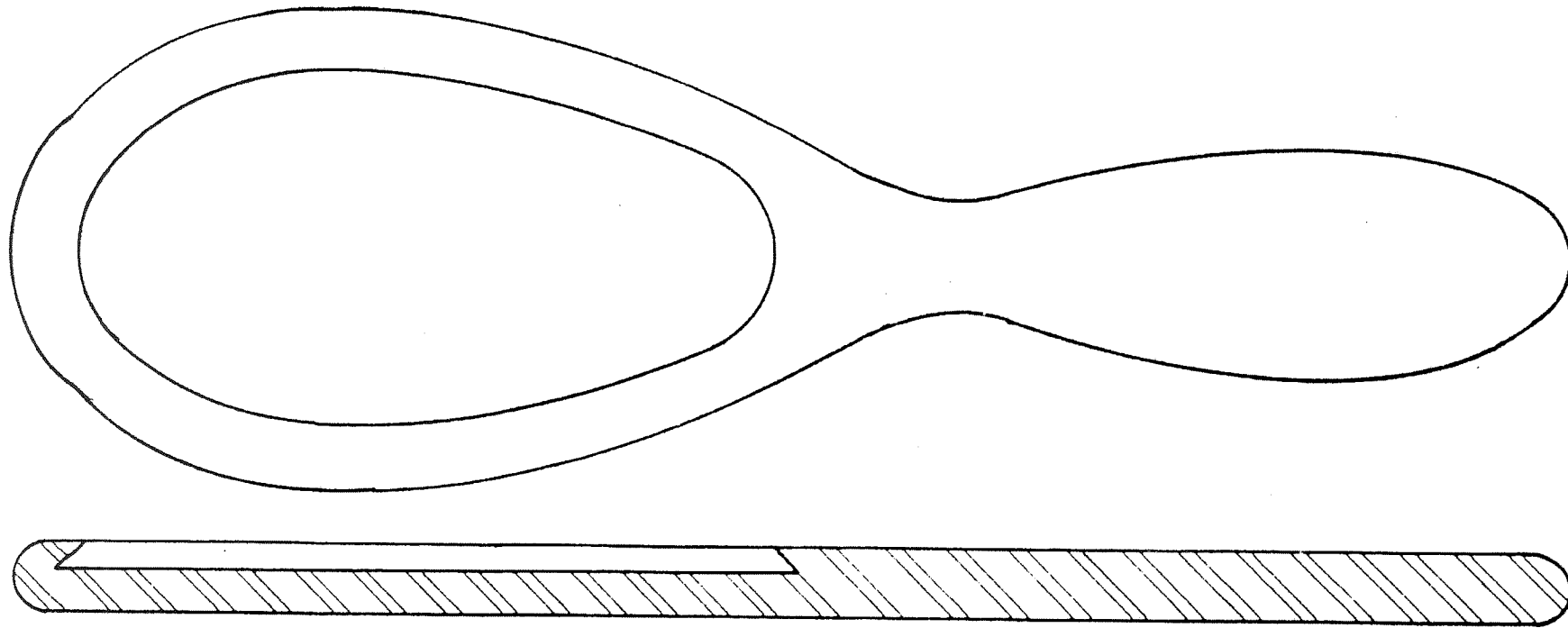

METHOD OF MAKING ROUTER JIGS FOR PRODUCING RECESSED BRUSH BACKS.

Prepare two jig bodies fitted with temporary hardwood rails and under each in turn pin (tack) the master sample brush back.

Mark the face of the jig with both outside profile of brush and shape of recess.

Mark face of jig.

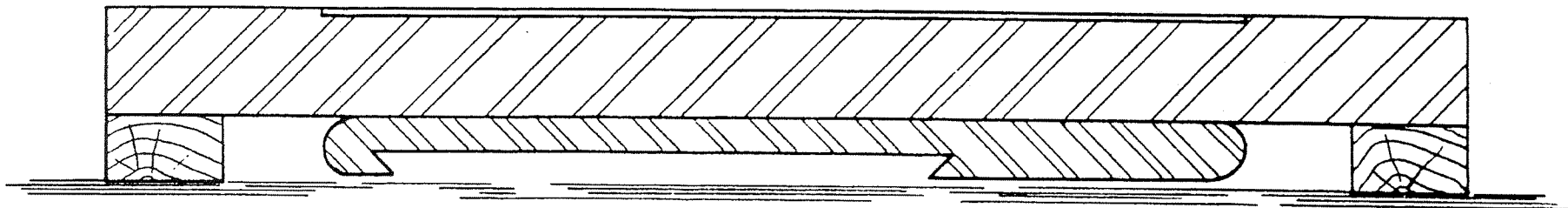

Template material can be mounted on face of jig and cut to shape during this stage of jig making.

FITTING TEMPLATES TO JIG BODIES.

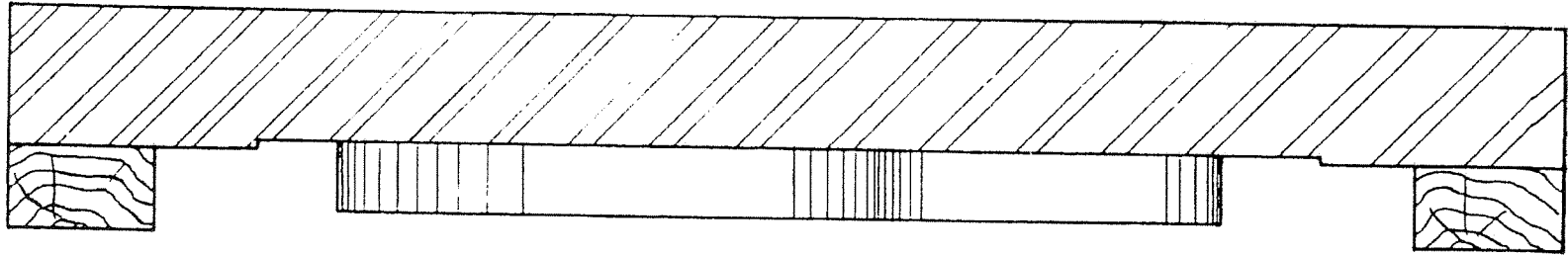

Remove temporary rails from jig body, turn jig over and fit hardwood rails on the opposite side, that is the marked face.

Fit template firmly, locating it from the previously made markings.

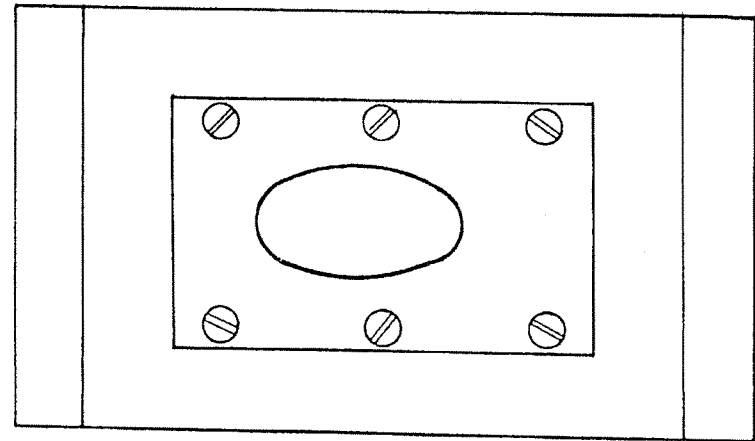
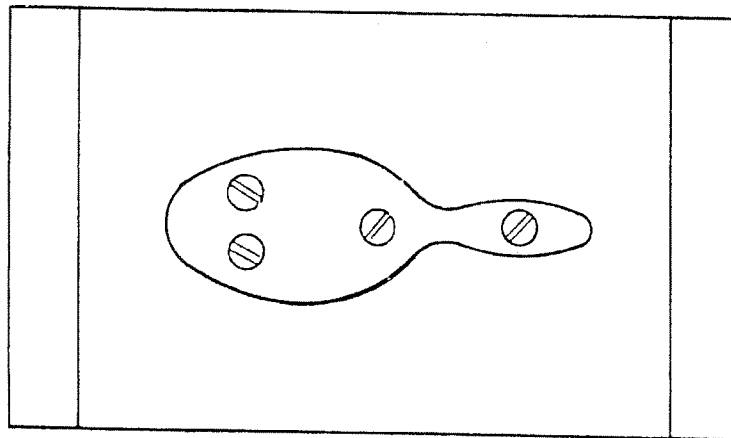

VIEW OF TEMPLATES FITTED TO JIG BODIES.

Jig for profiling and shaping 1st operation.

Jig for cutting out recess, 2nd operation.

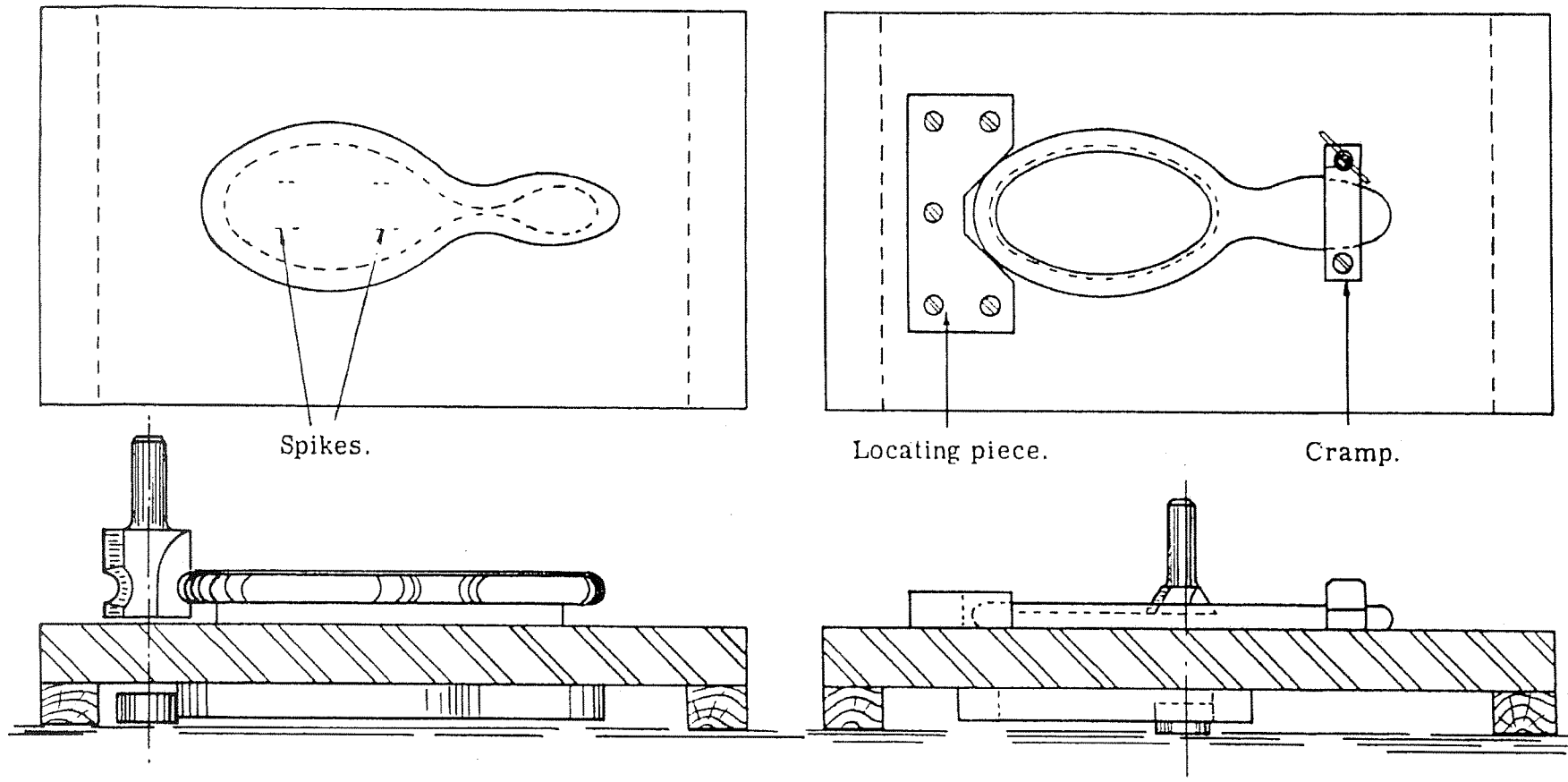

With templates firmly fixed the face of the jigs can be marked to show the position of templates. Fix screw for the holding spikes on the profiling jig as described on page 15 and locating piece and cramp on the recessing jig.

TYPES OF JIG REQUIRED FOR SHAPING SPECTACLE FRAMES ON ROUTER.

First Operation. Jig for cutting out eye pieces from rough sawn blank.

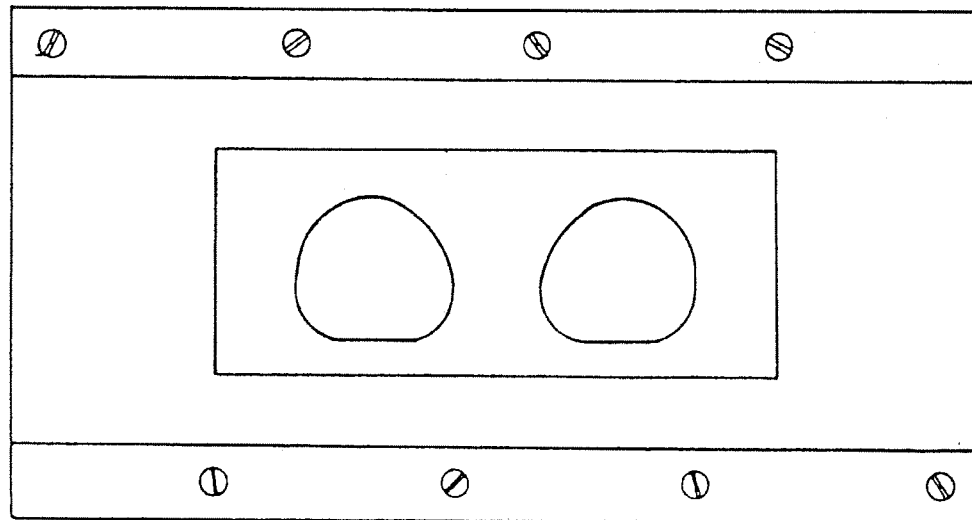
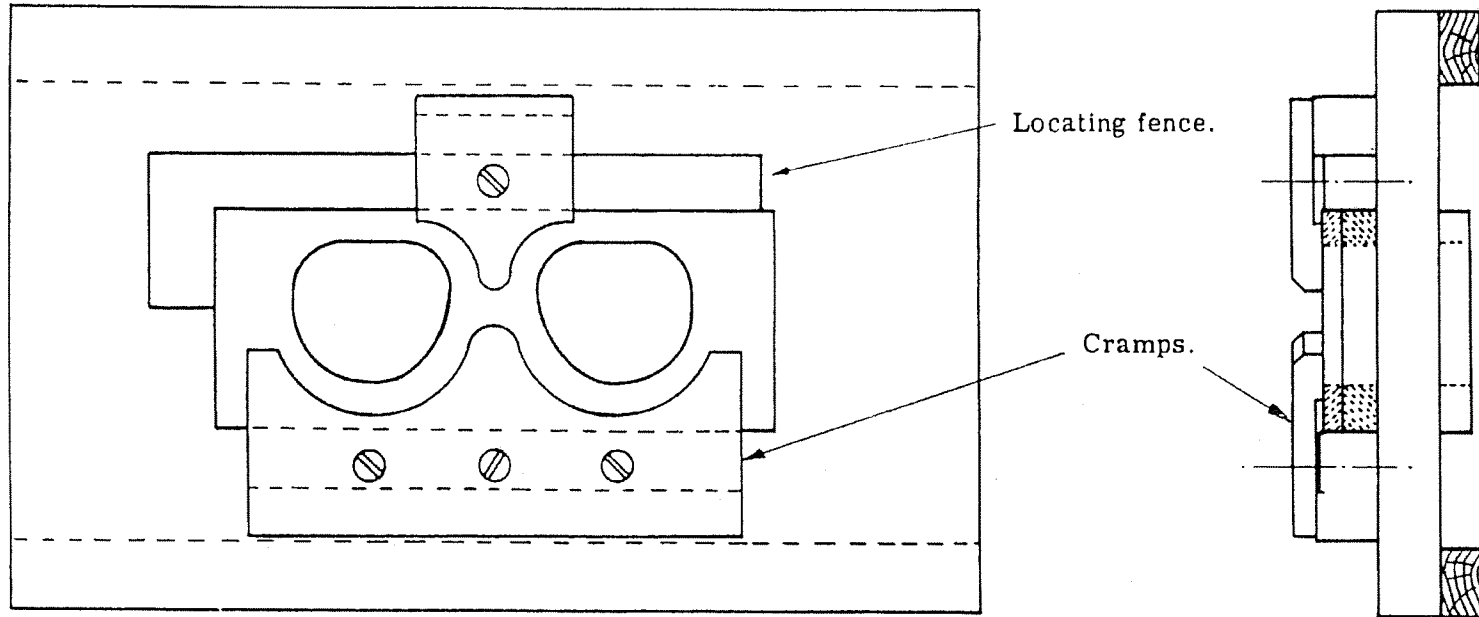

Underside of jig showing template.

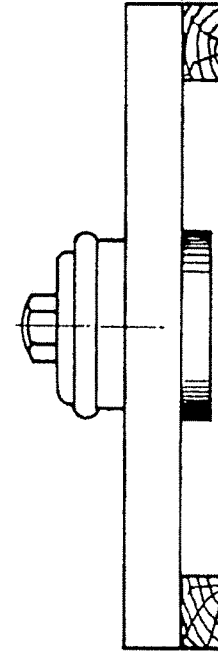
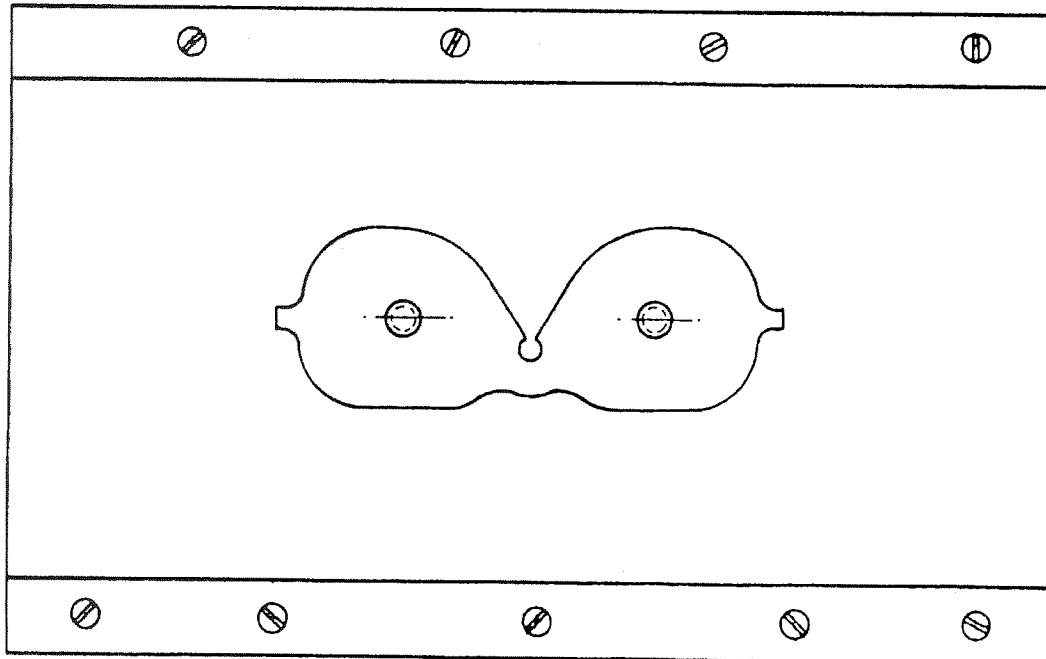
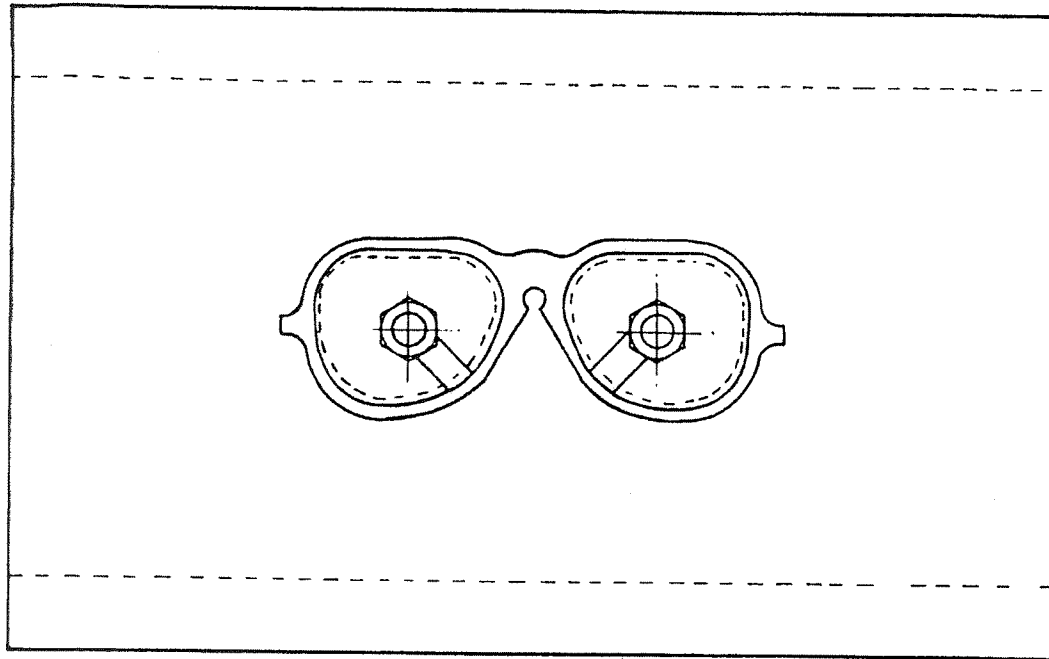

Jig for shaping outsides of spectacle frames.
Locating off previously cut eye-pieces.

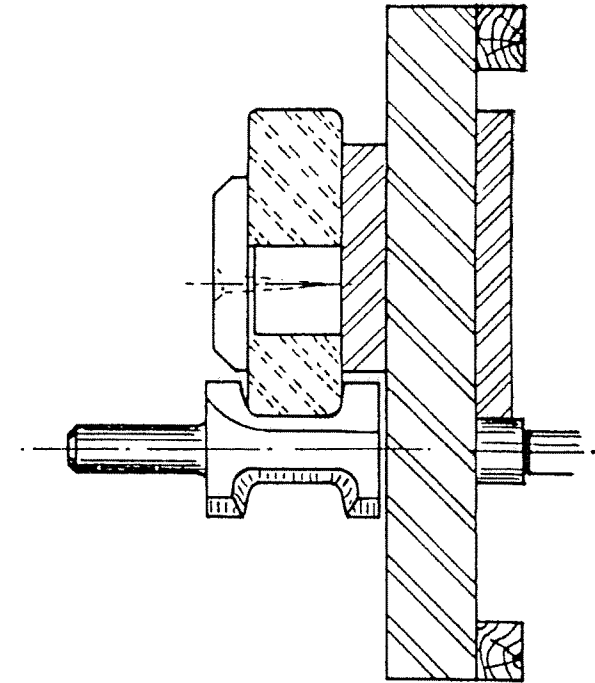
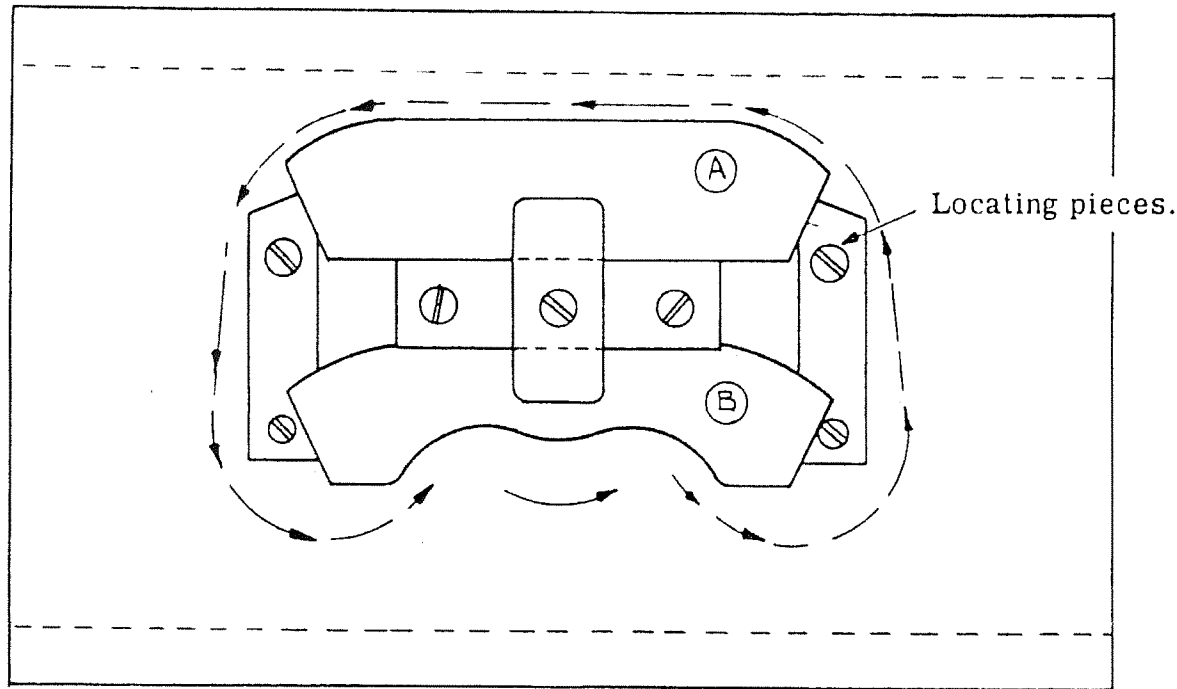

Many articles to be shaped on the router require machining all round, such as bag handles, coat hangers, some types of brush handles, etc. For this class of work it is advantageous to make a jig carrying two components.

METHOD OF OPERATING JIG:-

1. Put prepared blank in position A and rout outer edge.
2. Move shaped blank into position B locating off previously cut edge
3. Place a new blank in position A. With the jig now fully loaded a finished handle will be produced at each complete circuit of jig

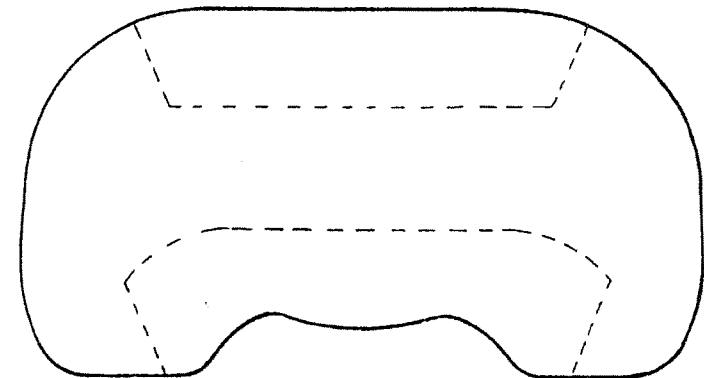

ROUTING OUT HANDHOLES IN CASE
END, SAW HANDLES, ETC.

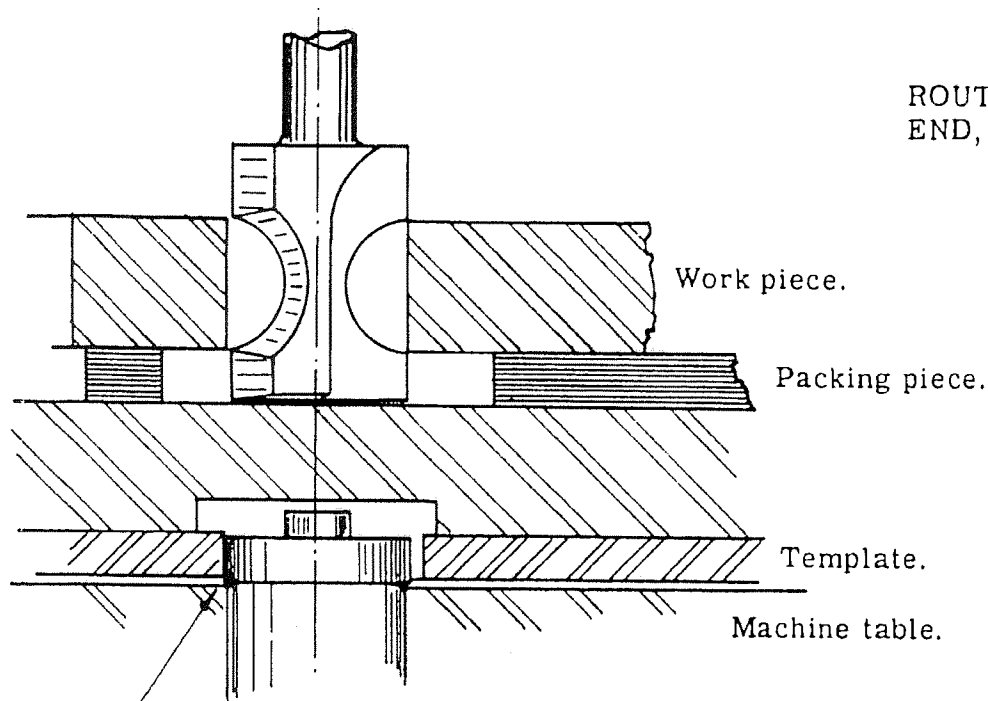

ALWAYS KEEP JIG MOVING WHILST
WORKING CUTTER THROUGH TIMBER.

When sinking cutter through timber the large diameter of former pin engages template, thus cutter is guided through timber without gashing sides of handhole.

When cutter has been worked through timber and reached position required, lower the former pin so that the small diameter engages the template. One pass around the template will then complete the handhole.

To avoid gashing the sides of handhole, when raising the cutter, after finishing the cut, return the large diameter of the former pin into position in the template.

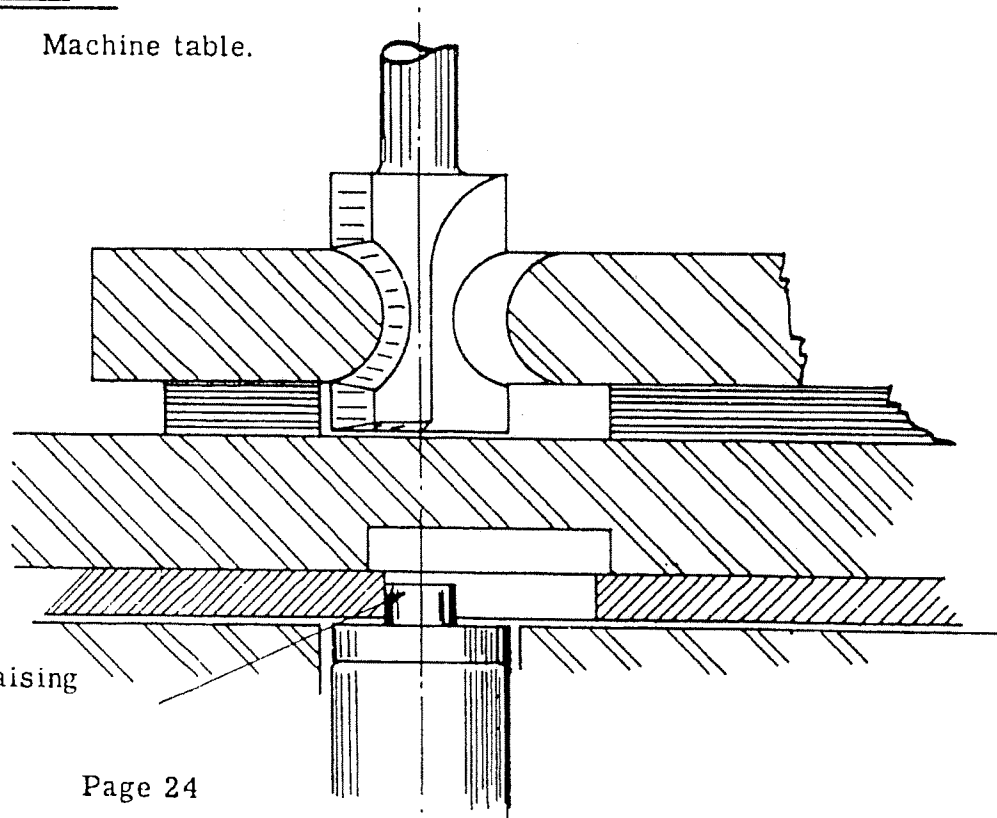

THE DIMENSIONS OF ANY WORK PIECE CAN BE ENLARGED OR DECREASED ON THE SAME JIG BY USING GUIDE PINS OF LARGER OR SMALLER DIAMETER THAN THE CUTTER.

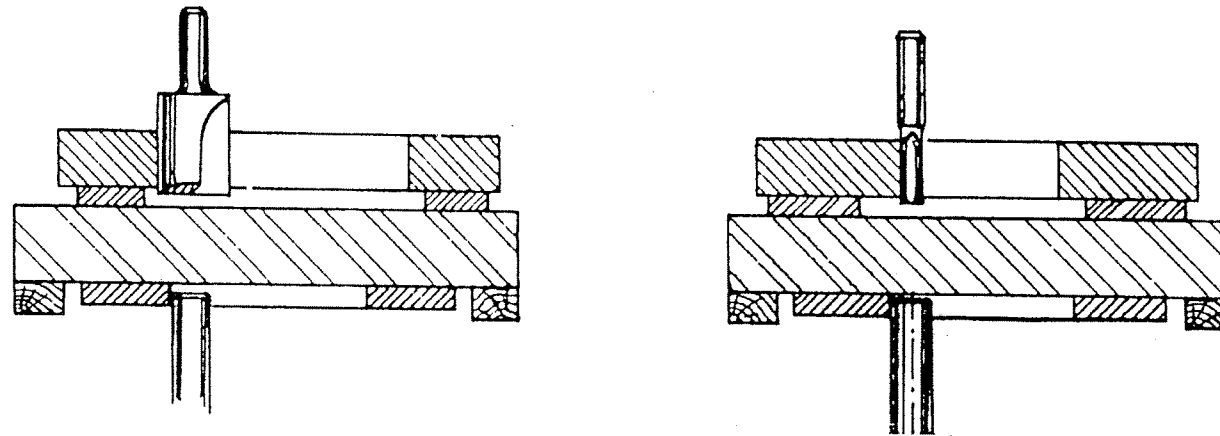
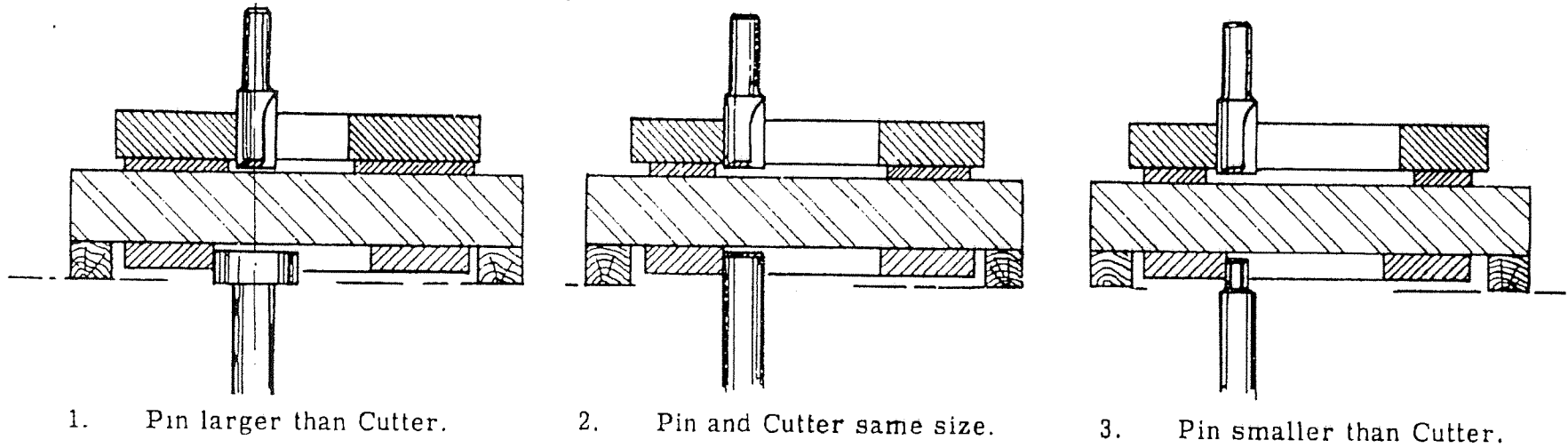

THE SAME RESULT CAN BE OBTAINED BY USING CUTTERS OF VARYING DIAMETER

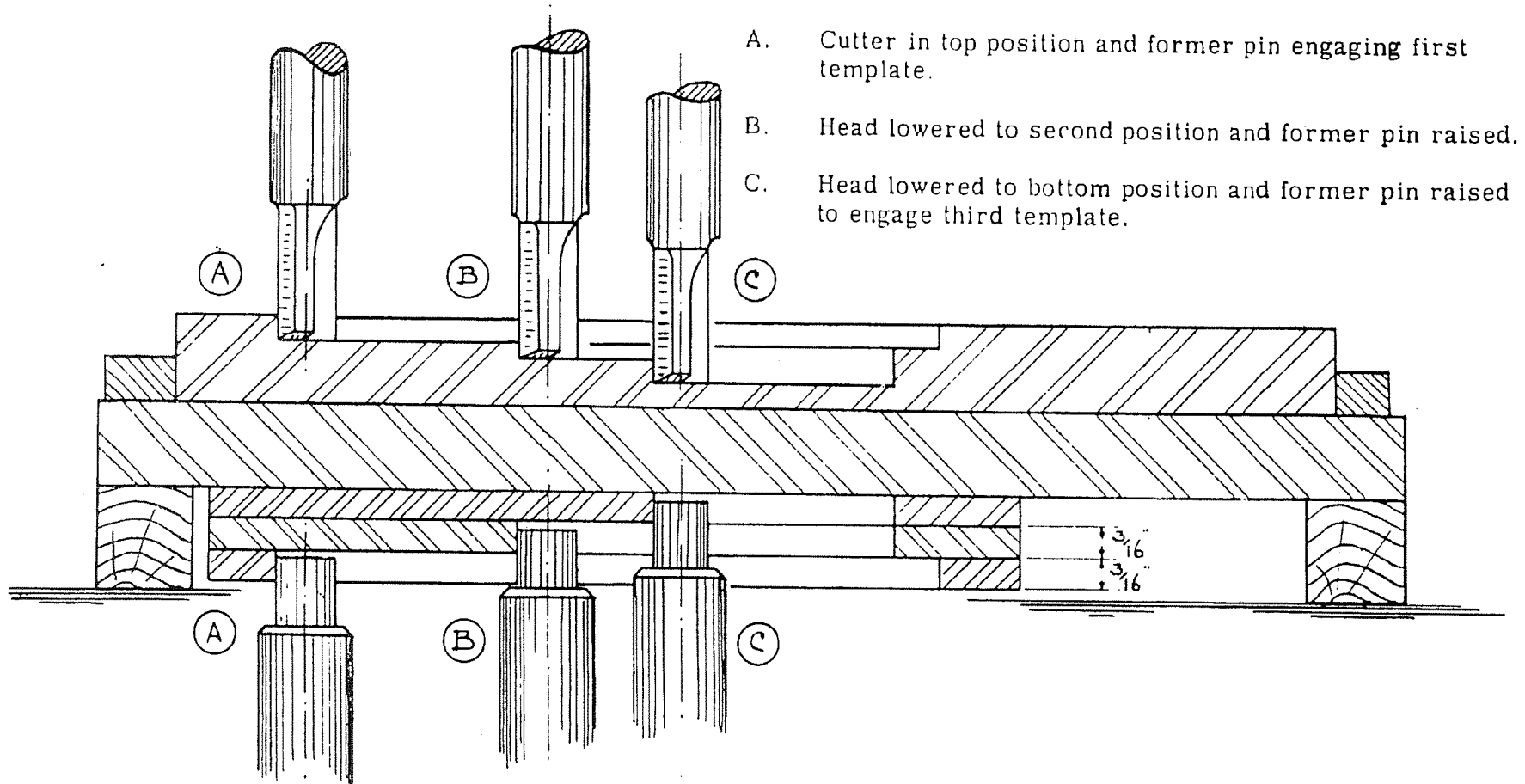

Recesses of various depths such as those in Cutlery trays, Tap and Die cases, types of Brush backs, etc. , can be worked by making a jig with multiple templates. Each template corresponding to the recesses of one depth. Mount the templates in one pack on the jig body and raising the former pin by the hand lever on the front of the machine table - each template can be engaged in succession. The various depths of cut are pre-set by the variable stops on the router head.



Finished article.

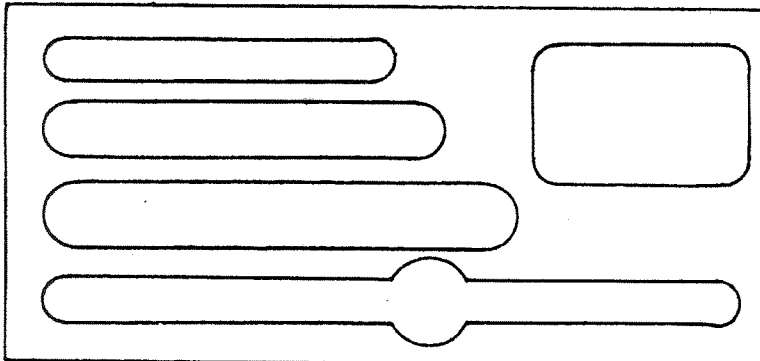

First template "A"

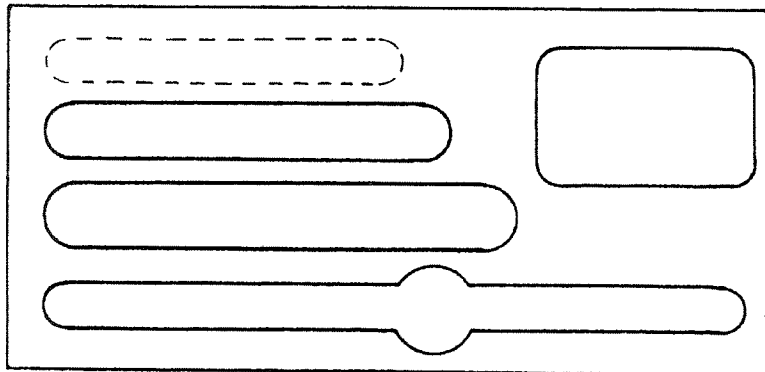

Second template "B"

Section across tray.

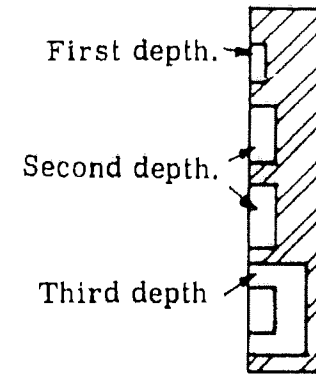

First depth.

Second depth.

Third depth.

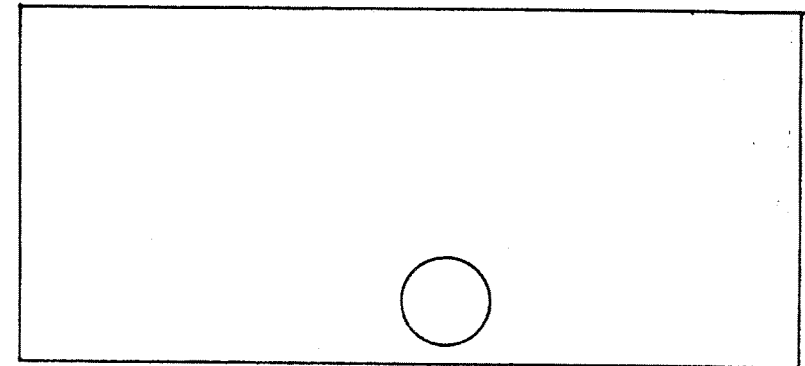

Third template "C"

Details of templates for working recesses of various depths.

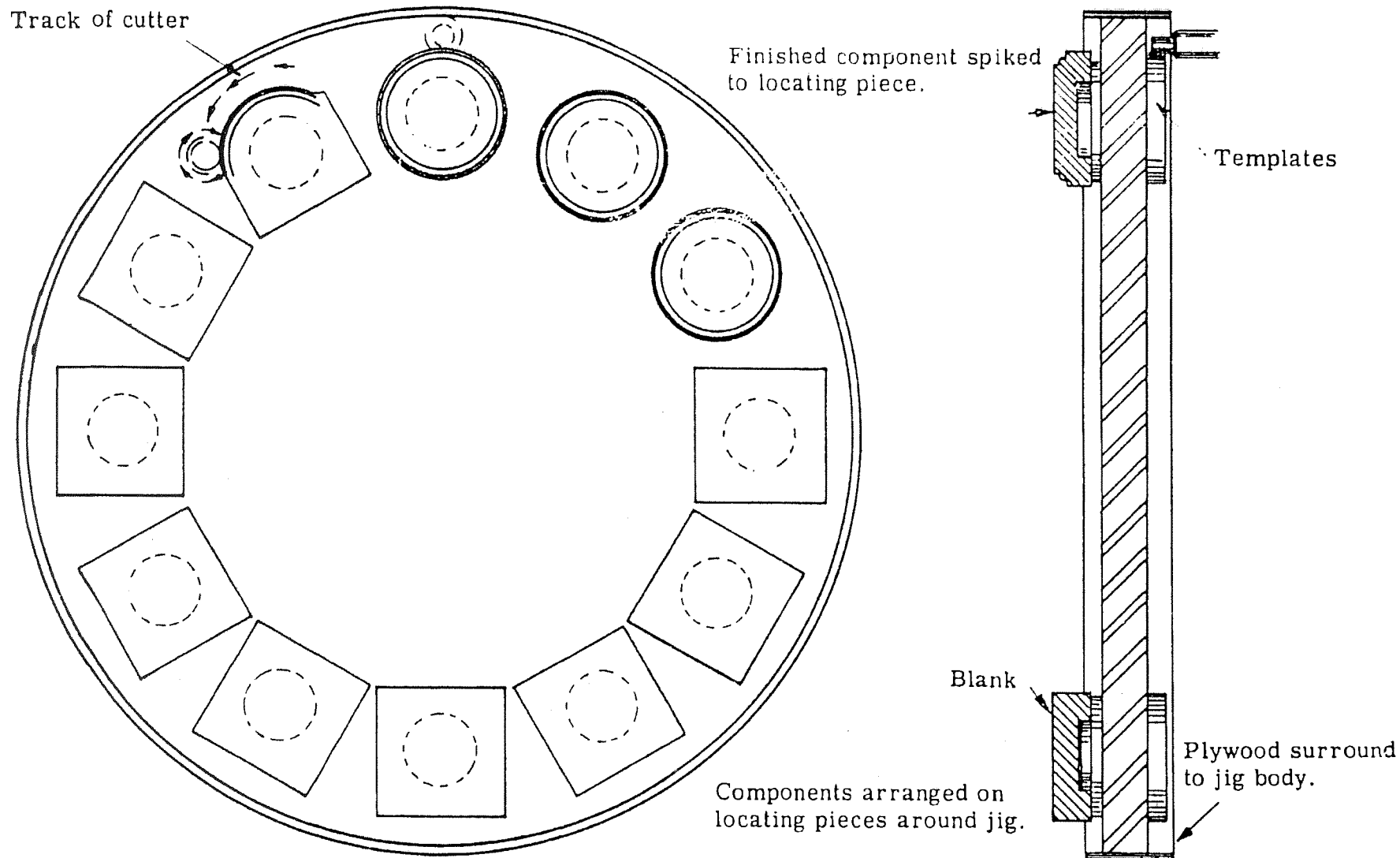

When large quantities of any small articles such as electric light ceiling rosettes, etc., are to be made, it is often advantageous to build a circular jig carrying a number of components. By using this type of jig the operator's position in relation to the machine is constant and excessive movements of the hands avoided.

To maintain constant production, duplicate jigs can be used, one being reloaded whilst operator routs with second jig. This eliminates idle machine time.

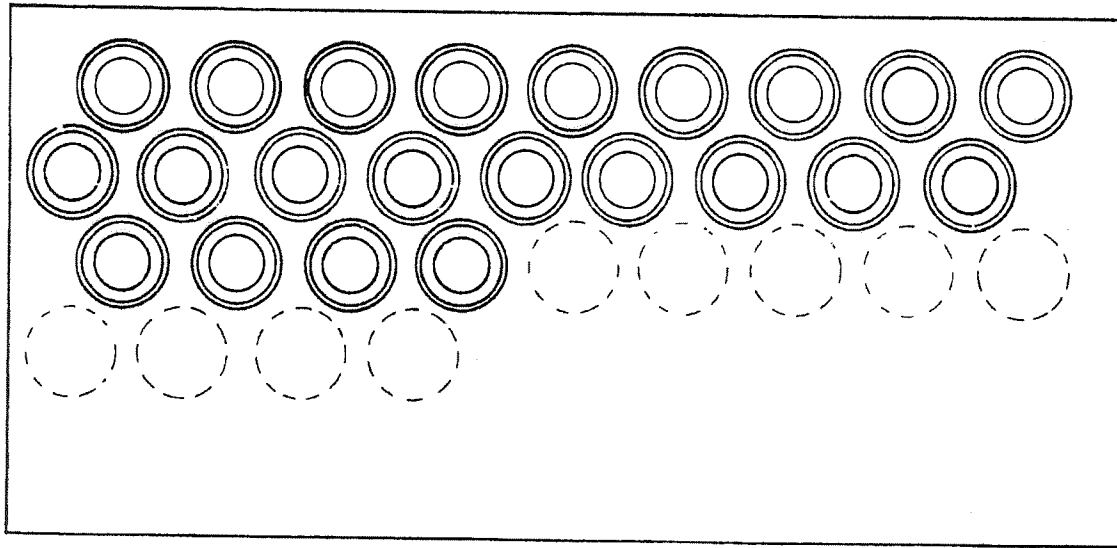

Routed face of wood.

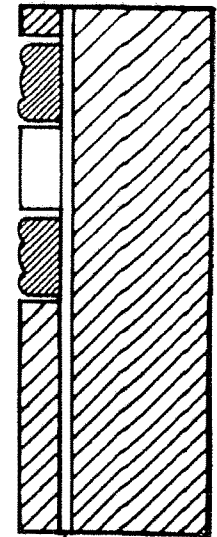

Saw-cut.

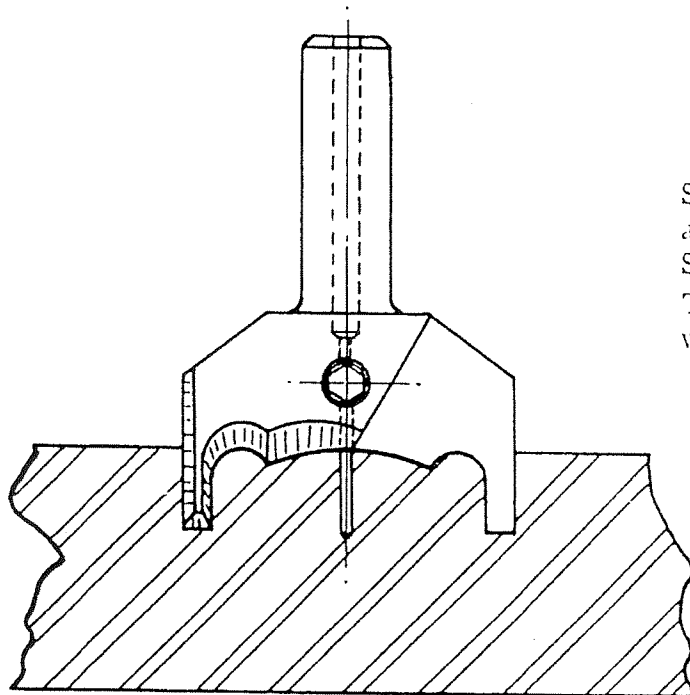

Small circular objects and wheels for toys can be made by sinking a special shaped cutter into the surface of any suitable wood. Saw off the routed face then the wheels will fall loose. The routing operation can then be repeated on the stock piece of wood if of suitable thickness.

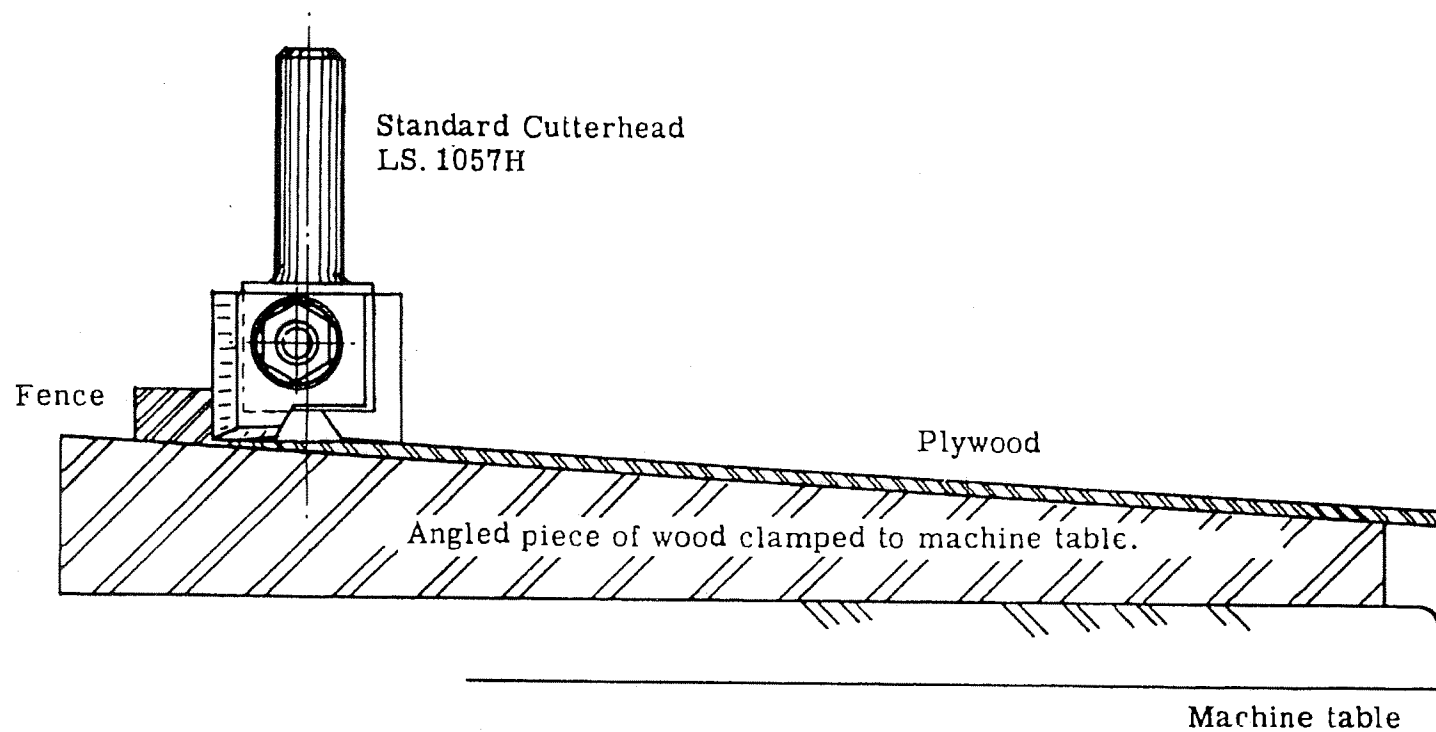

METHOD OF SCARFING PLYWOOD, ETC., ON A WADKIN ROUTER.

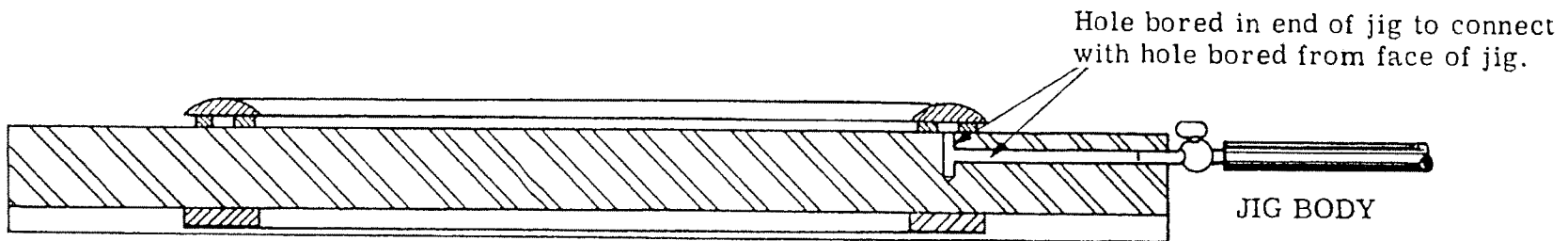
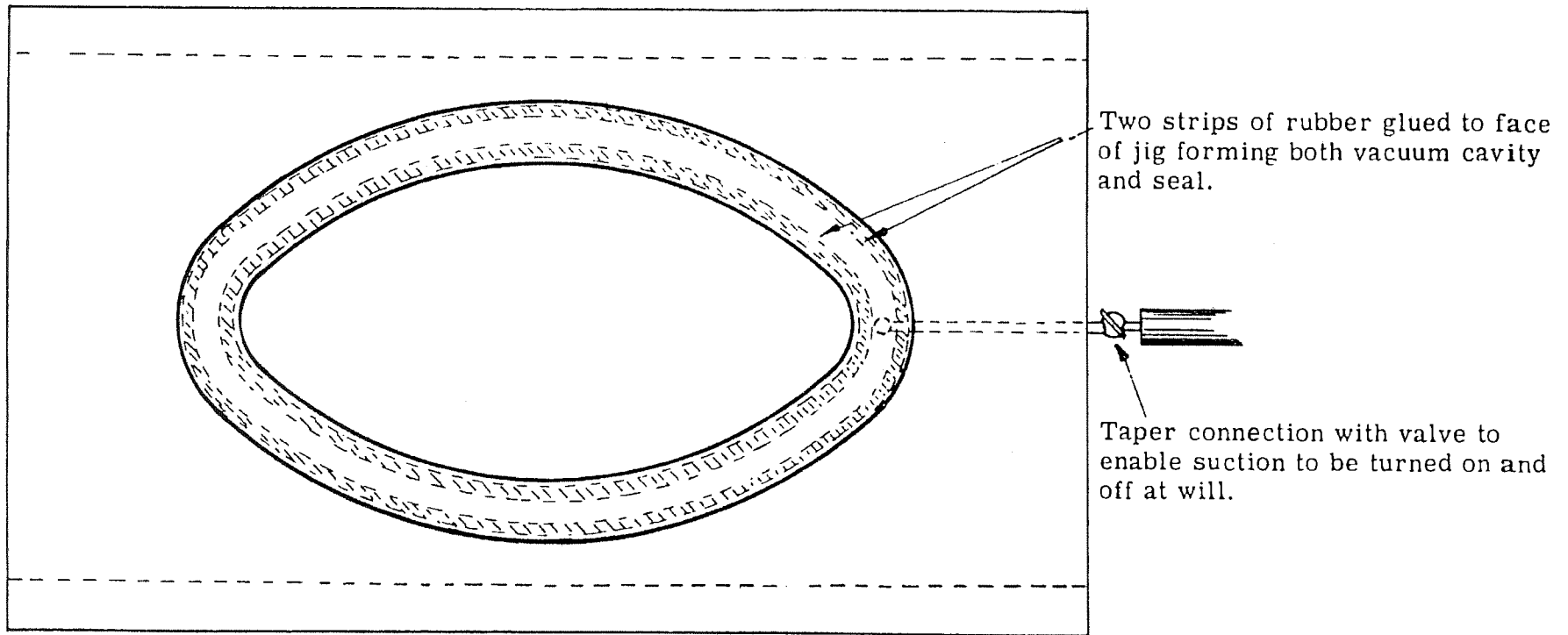

Plastic components, draughtsmen's protractors, or any light article requiring routing all round can be produced by making a jig whereby the components are held by suction. Two rubber strips are glued to face of jig conforming to the profile of the component. Place the blank component on the rubber and exhaust the air from between the strips. Blank will now be held firmly during routing.



Type of jig required for
shaping and moulding curved
chair backs, etc.

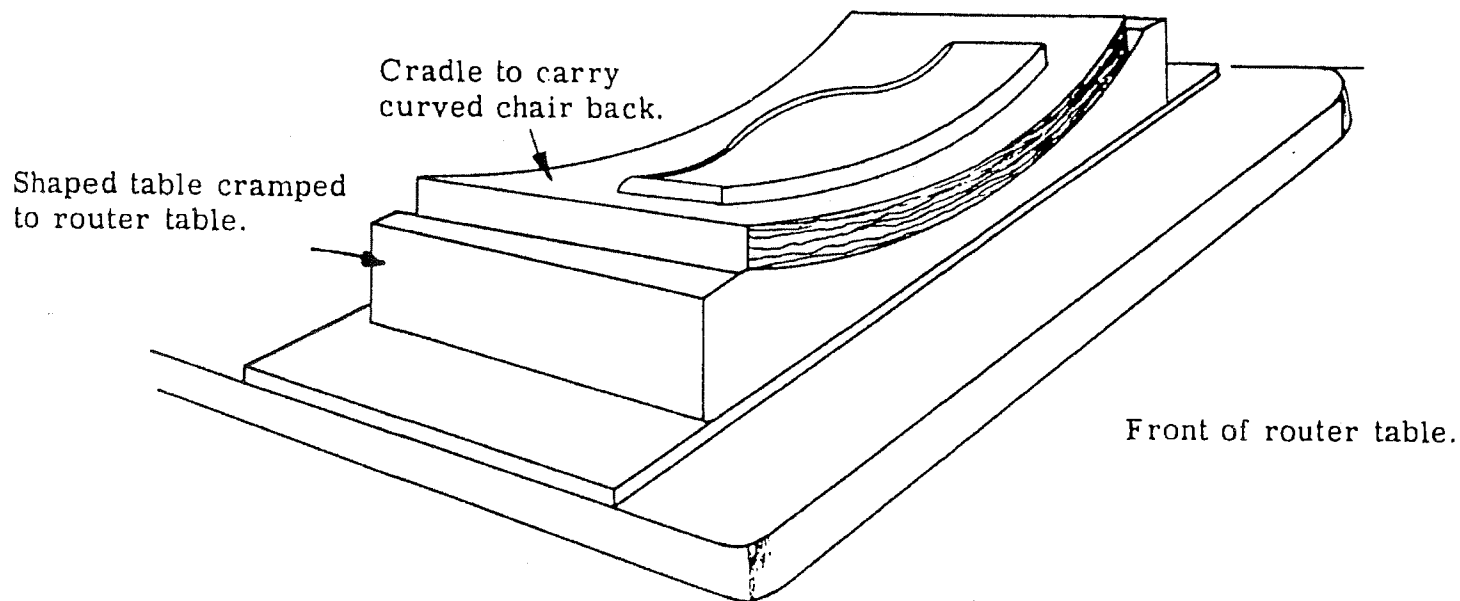
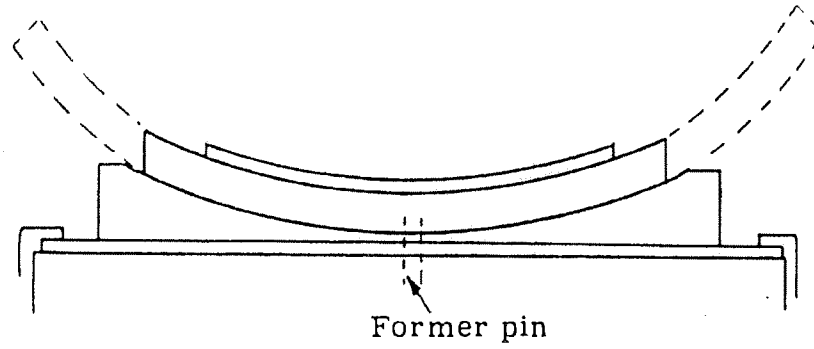

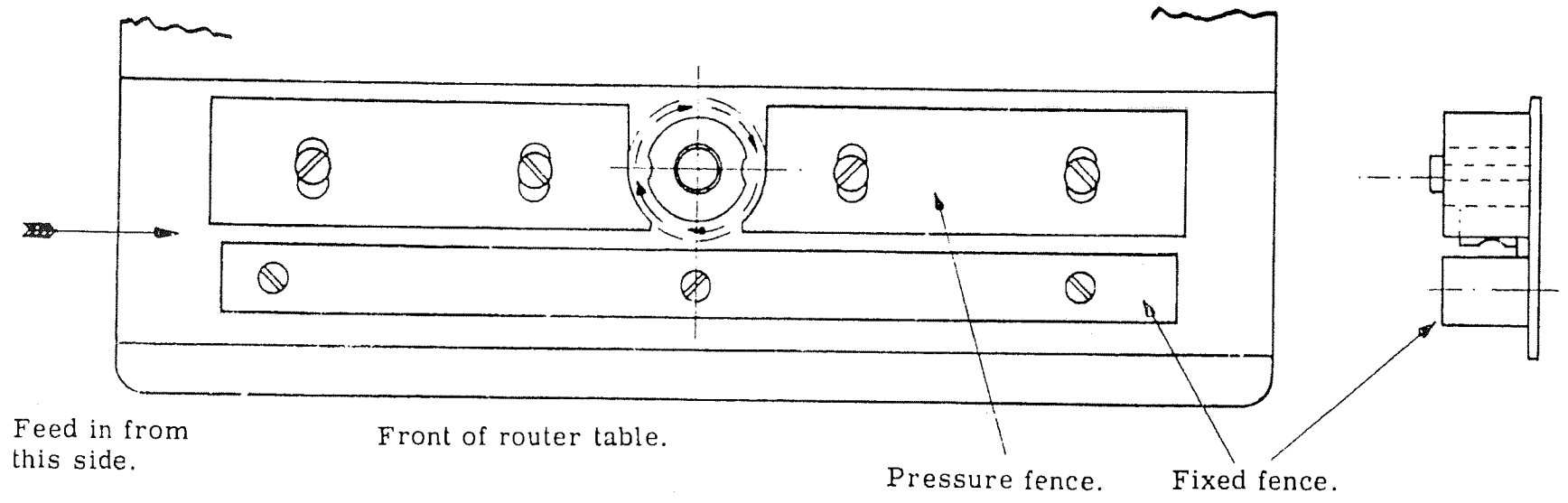

Feed in from this side.

Front of router table.

Pressure fence.

Fixed fence.

Simple type of pressure fence to enable small mouldings, beads, etc., and thicknessing to be worked on Router.

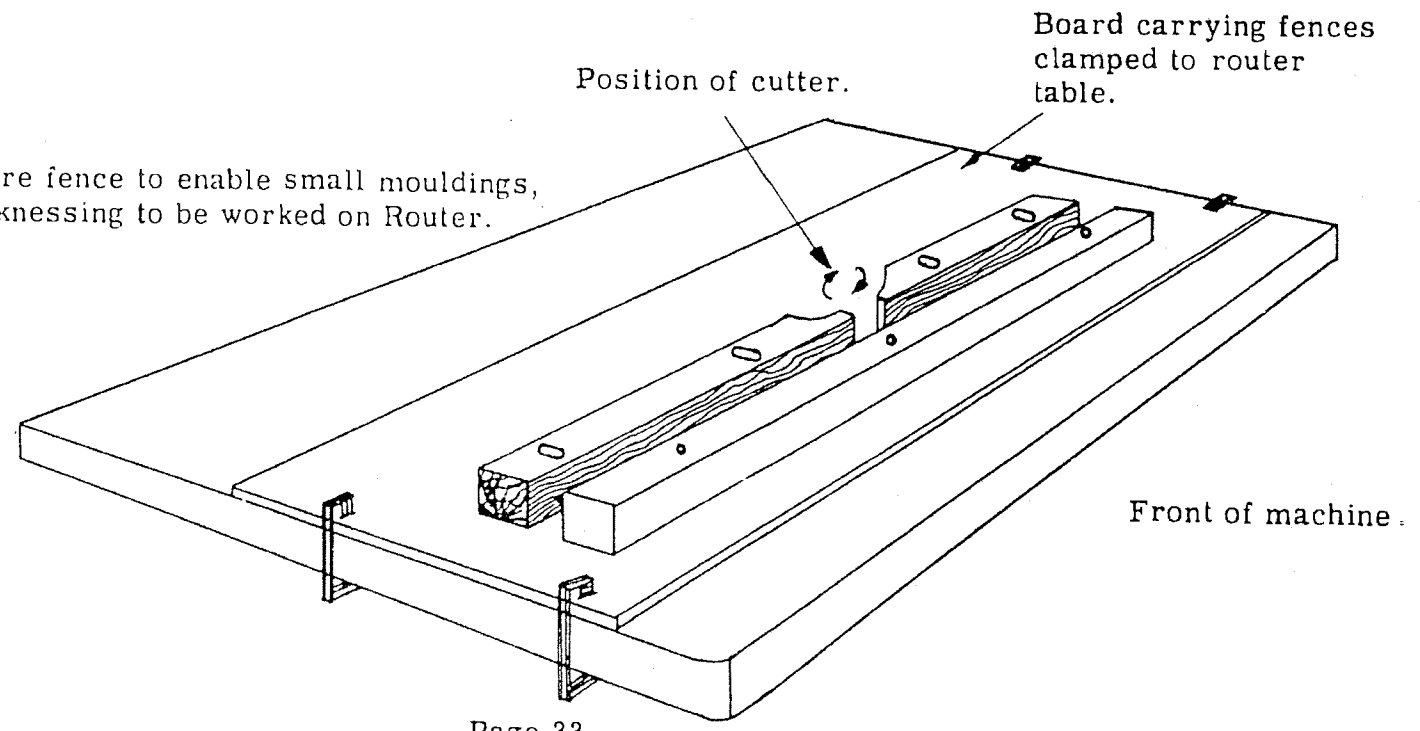

Position of cutter.

Board carrying fences clamped to router table.

Front of machine.

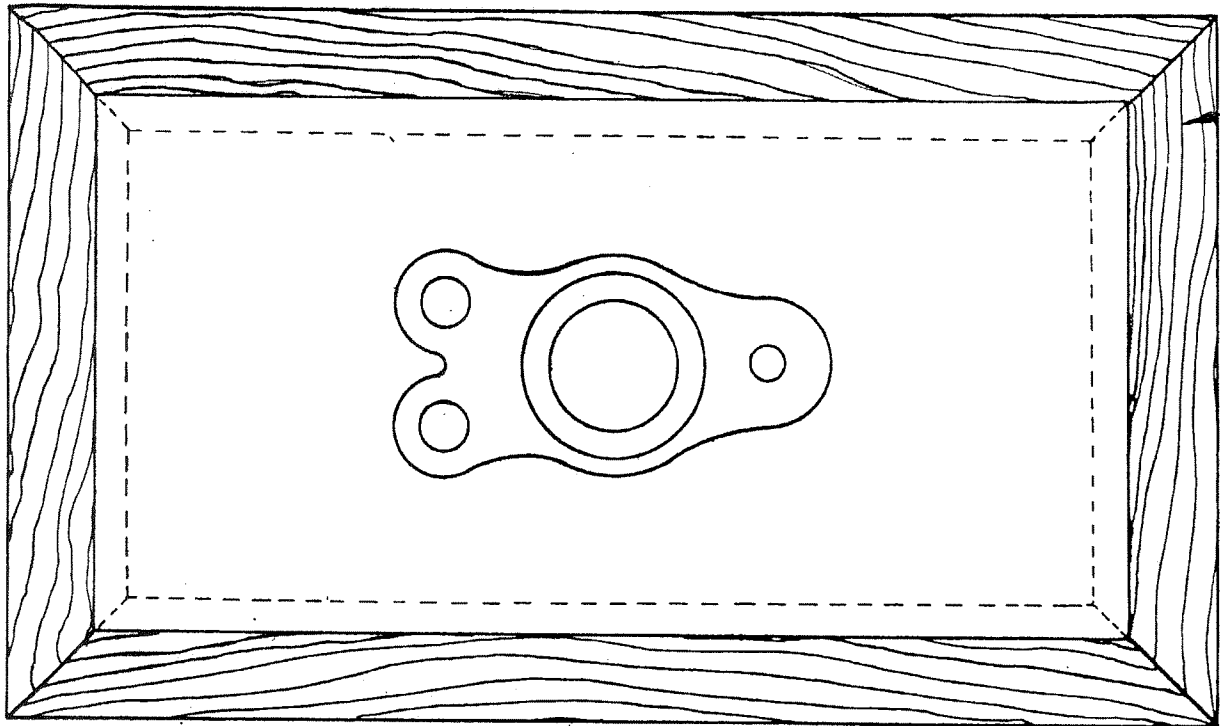

Hardwood frame
around composition
or aluminium jig body.

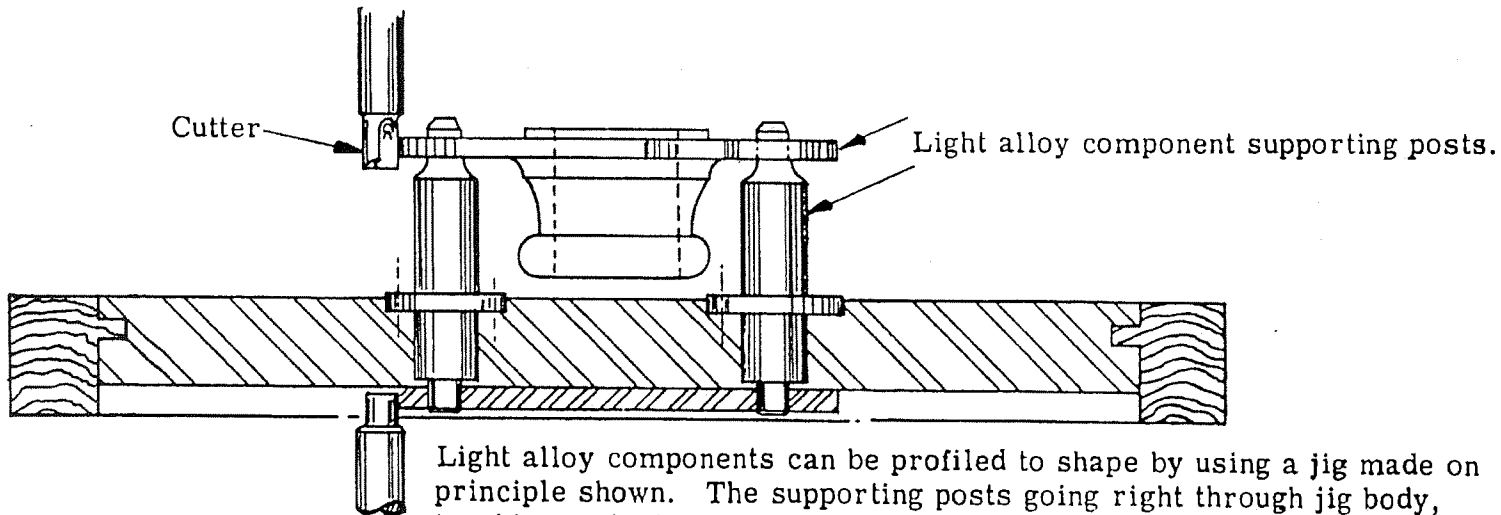

Light alloy components can be profiled to shape by using a jig made on principle shown. The supporting posts going right through jig body, tracking up both template and component, the template having exactly the same profile and tooling holes as component.

ECCENTRIC CHUCKS

For slotting, small mortices, grooving, etc., where constant cutting diameter is important, the use of an eccentric chuck is advised.

The cutters are only sharpened inside the flute. Providing the cutting edge is always set in position, between the 30° and 50° marks as shown in diagram, the effective cutting diameter will never decrease.

It is important that the right combinations of cutter and chuck as set out on the chart are maintained. If not, cutter burning and poor work will result. Eccentric chucks must be balanced carefully.

SIZE OF CHUCK	DIAMETER OF CUTTER				EFFECTIVE CUTTING DIAMETERS			
1/32	$\frac{1}{8}$		5/32	3/16	5/32	3/16		7/32
3/64	$\frac{1}{8}$	5/32	3/16	7/32	11/64	13/64	15/64	17/64
1/16	3/16	7/32	$\frac{1}{4}$	5/16	$\frac{1}{4}$	9/32	5/16	$\frac{3}{8}$
3/32	$\frac{1}{4}$		5/16	$\frac{3}{8}$	11/32		13/32	15/32
$\frac{1}{8}$	5/16	$\frac{3}{8}$	13/32	7/16	7/16	$\frac{1}{2}$	17/32	9/16
5/32	$\frac{3}{8}$	13/32	7/16	15/16	17/32	9/16	19/32	$\frac{5}{8}$

DIMENSIONS OF CUTTERS FOR ECCENTRIC CHUCKS.

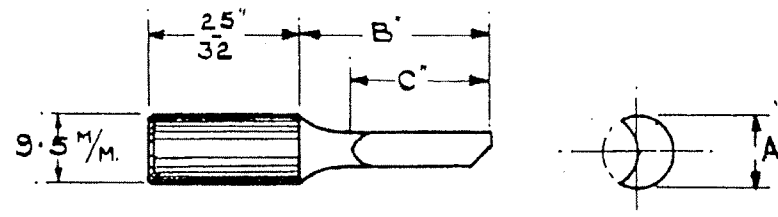

A	$\frac{1}{8}$ "	5/32"	3/16"	7/32"	$\frac{1}{4}$ "	5/16"	$\frac{3}{8}$ "	13/32"	7/16"	15/32"	$\frac{1}{2}$ "
B	31/32"	31/32"	31/32"	31/32"	1. 3/16"	1 $\frac{3}{8}$ "	1 $\frac{3}{4}$ "	1 $\frac{3}{4}$ "	1 $\frac{3}{4}$ "	1 $\frac{3}{4}$ "	1 $\frac{3}{4}$ "
C	9/16"	9/16"	$\frac{5}{8}$ "	$\frac{5}{8}$ "	$\frac{3}{4}$ "	7/8"	1 $\frac{1}{8}$ "	1 $\frac{1}{8}$ "	1. 3/16"	1. 3/16"	1 $\frac{1}{4}$ "

Eccentric chuck.

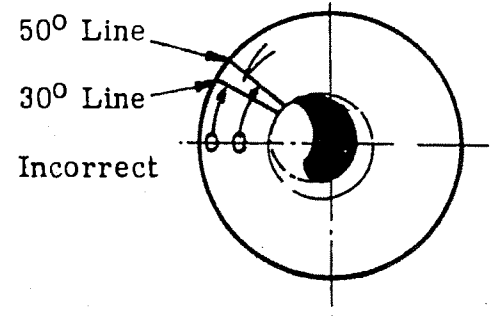
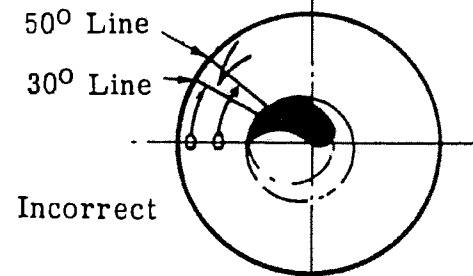
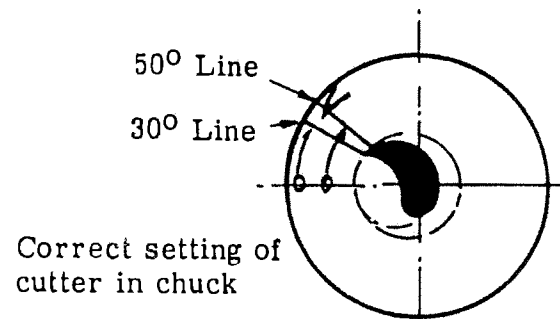
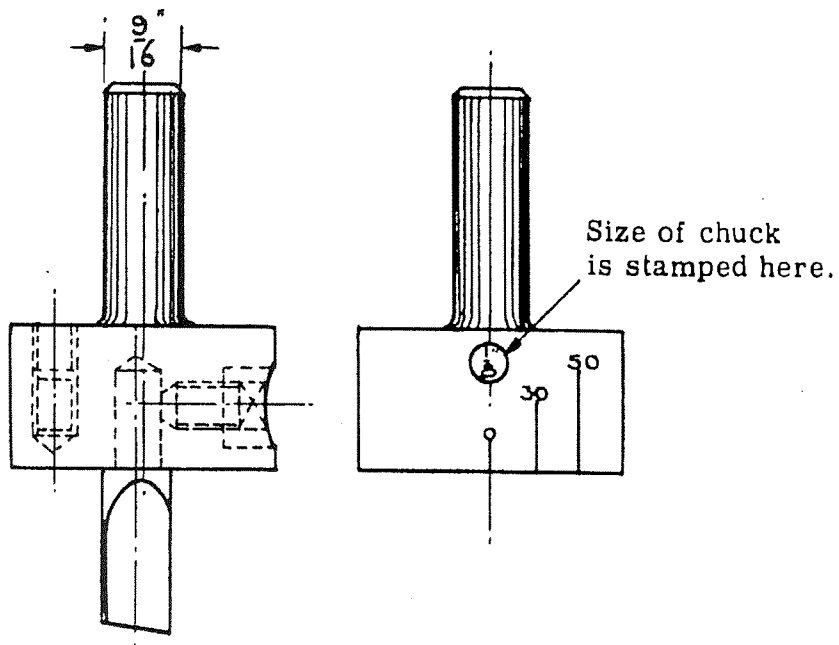

To find the cutting diameter of any respective chuck and cutter, add the chuck size to the diameter of the cutter. The cutting edge of the cutter must be either on or between the lines marked 30°-50° to ensure cutter clearance and the best cutting angles.

With cutter so set a chuck marked 1/16" and a cutter 1/4" diameter will cut 5/16" diameter.

It is important that an eccentric chuck should be balanced every time the cutter is changed. The cutter being set in its correct cutting position before the balance operation is carried out.

Balancing plate is levelled by means of three adjustable screws. Then the chuck is inserted in the balancing roller and the correct balance is obtained by inserting or withdrawing balancing screws. When the chuck is perfectly in balance the roller will come to rest in any position.

The plate can be levelled by testing with the balancing roller only, or spirit level. Great care must be taken with the roller, never allowing the rims to be bruised.

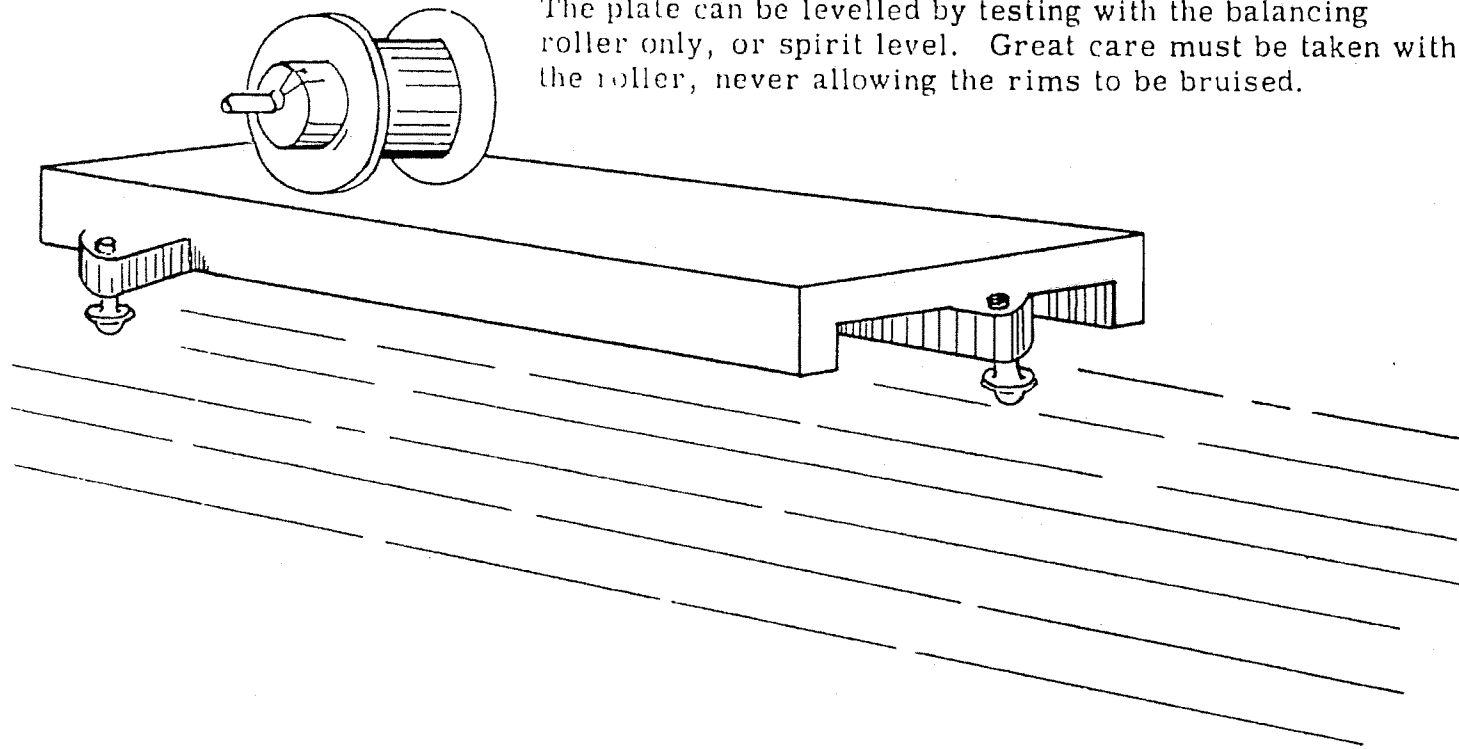

EXAMPLES OF EXTREME CUTS
POSSIBLE ON WADKIN ROUTER.

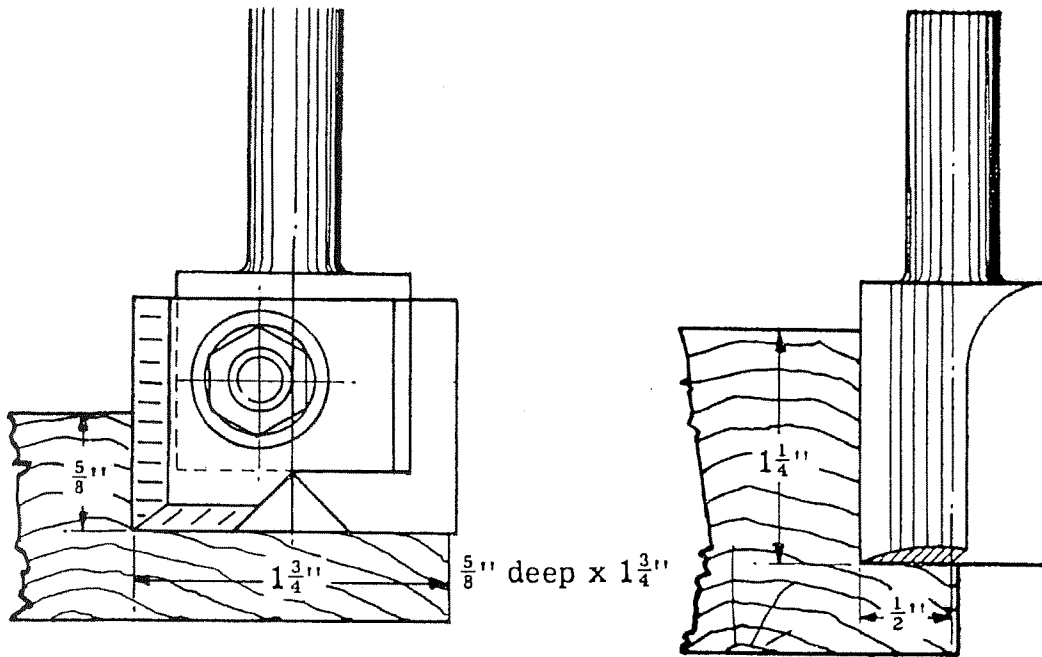

Rebating across or with the grain.

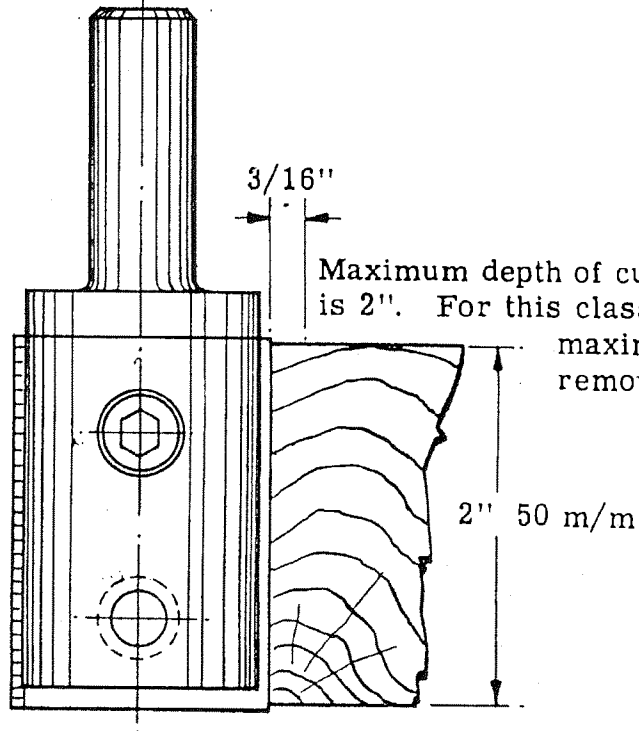
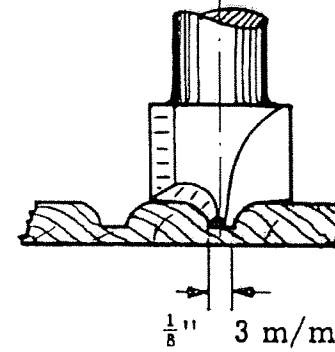

Maximum depth of cut when edging shaped work is 2". For this class of routing 3/16" is the maximum amount of wood to remove continuously.

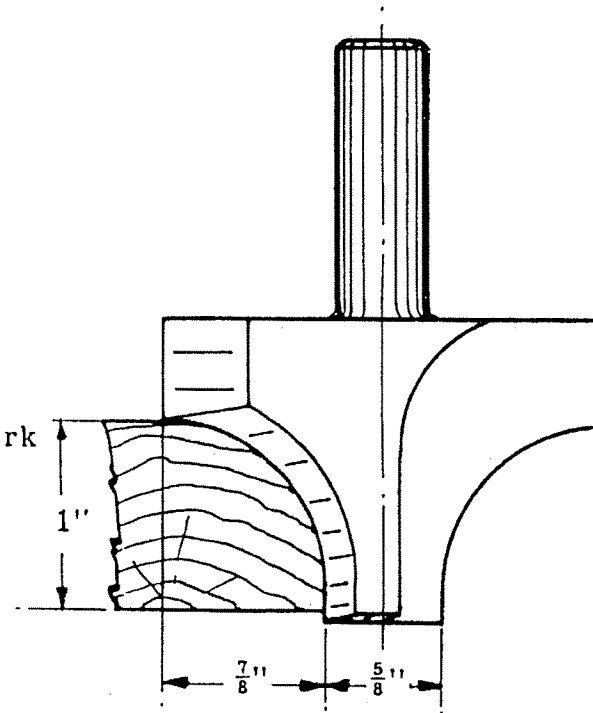

Maximum dimension
of moulding on Router.

EXAMPLES OF EXTREME CUTS POSSIBLE ON WADKIN ROUTERS.

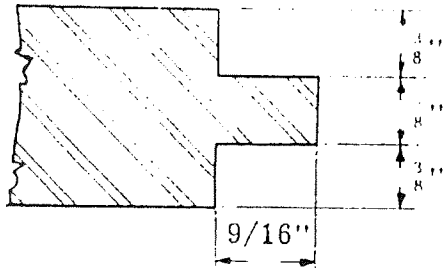

Maximum sizes double rebate

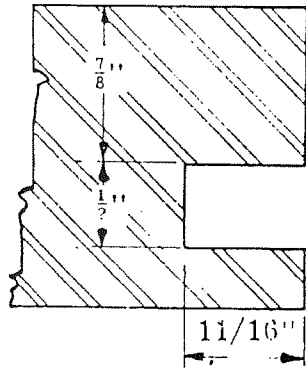

Maximum size of groove

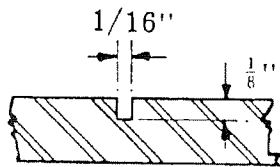

Smallest groove possible

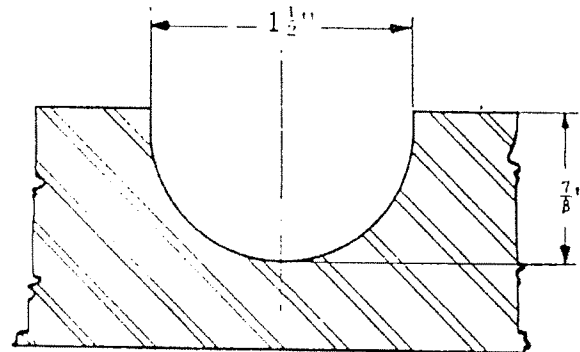
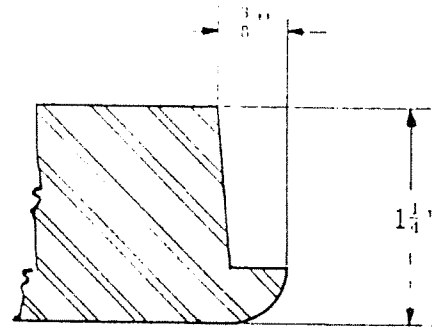

Maximum size of flute

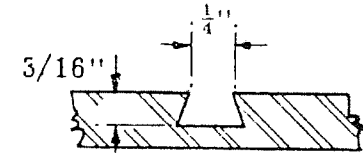
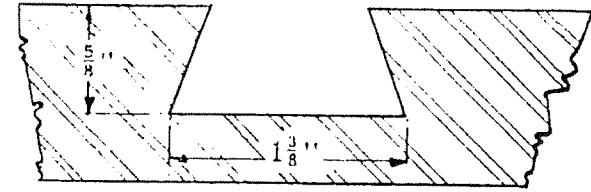

Maximum and minimum sizes of dovetail grooves

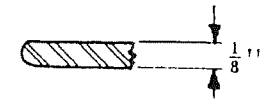
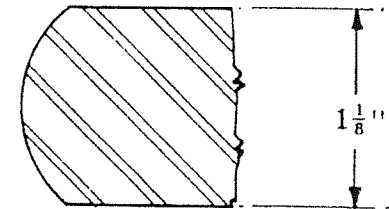

Maximum and minimum sizes of nosing (rounding) cutters Type 23.

A Spring Pressure Cramp can be fitted to the Router Head to ensure that hardwood components are pressed onto the jig. Also preventing the component lifting off the spikes. The spring pressure helps to provide accurate routing.

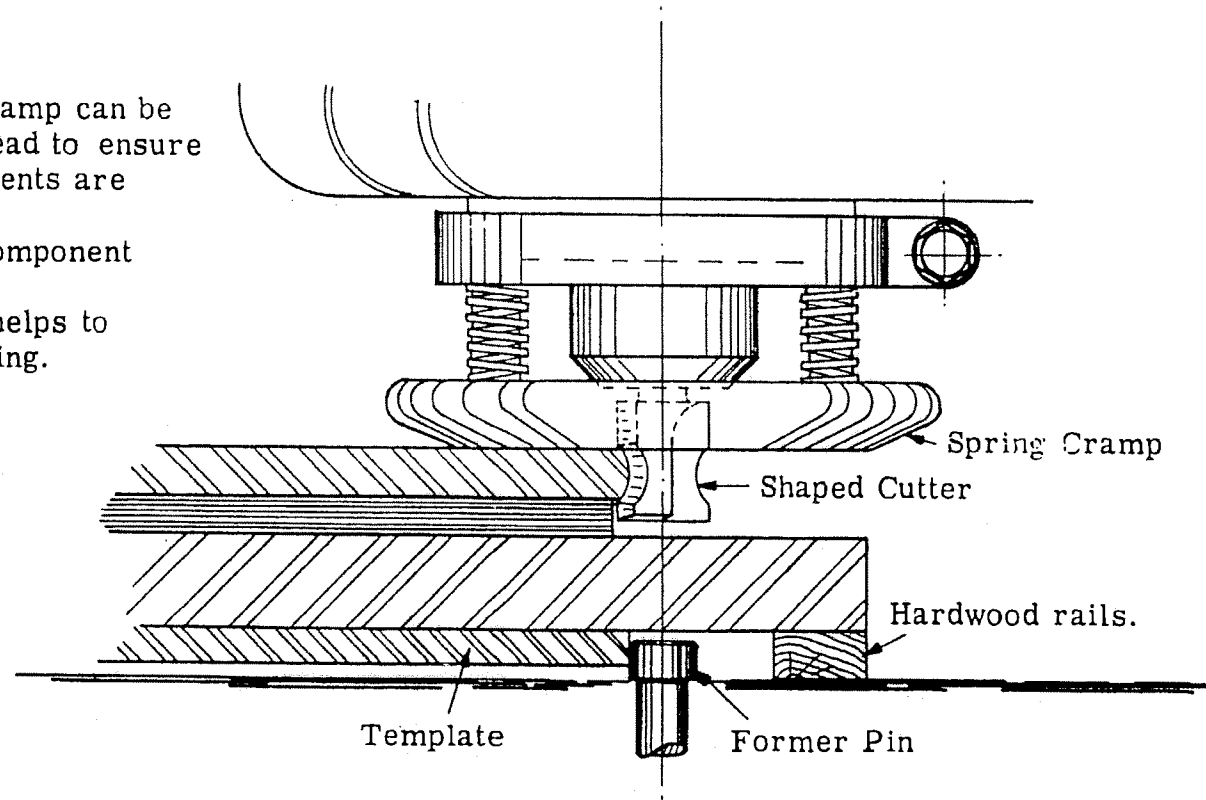

Applicable when routing thin plywood, veneers, plastics, and hardwood components which are held to the jig by spikes.

Double Edged Cutters - Panel Type 4.

Relief or clearance always increasing from the cutting edge

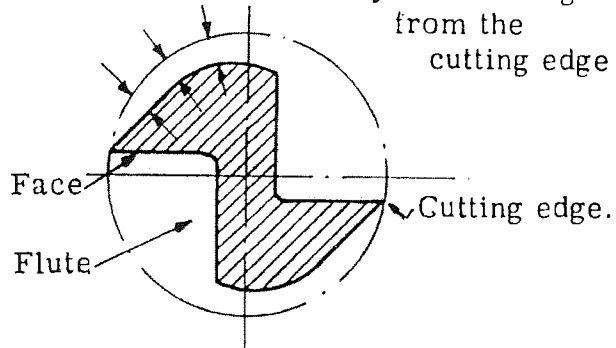

Cutter as sent out by Wadkin Ltd.

Single Edge Cutters-Spoon Type 1.

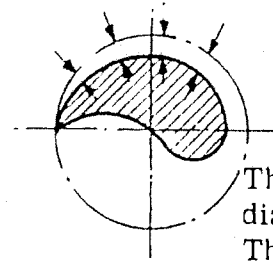

This type of cutter is used where cutter diameters of $\frac{3}{8}$ " or less are necessary. The relief or clearance of this type of cutter must never be ground free-hand. Always grind and hone spoon cutters in the flute, maintaining the original form as near as possible.

Hump behind cutting edge.

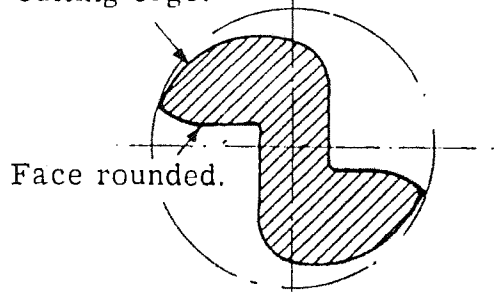

Cutter incorrectly ground and honed.

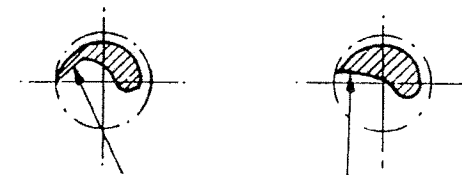

Incorrect grinding will result in cutter breakage and bad work.

Face ground straight.

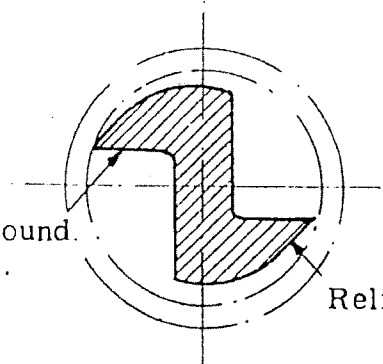

Cutter reground correctly.

CUTTER GRINDING

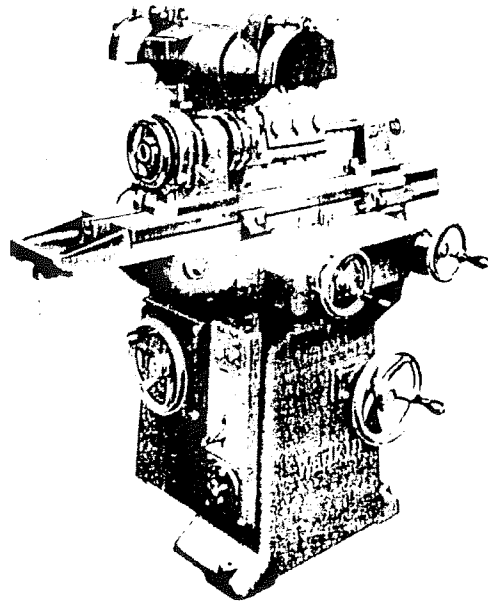

To obtain consistently good work from high speed routing it is essential that the cutters are kept sharpened and ground correctly. This can only be assured when suitable equipment is available. The ideal grinder for this purpose is the Universal Type N. H. shown left. Not only will this machine deal with all router cutters, but it is indispensable for maintaining every type of cutter equipment used in a woodworking plant, excluding long planer knives.

NOTE - Where a suitable grinder is already installed we can supply the set of fixtures for router cutters as used on this machine.

Where the amount of cutter grinding does not justify a Universal Grinder we recommend the N. U. type machine shown right. This machine has been specially designed for router cutters. It is self-contained and provided with a precision grinding spindle. Table has movement in three directions and is designed to take fixtures for handling all types of router cutters.

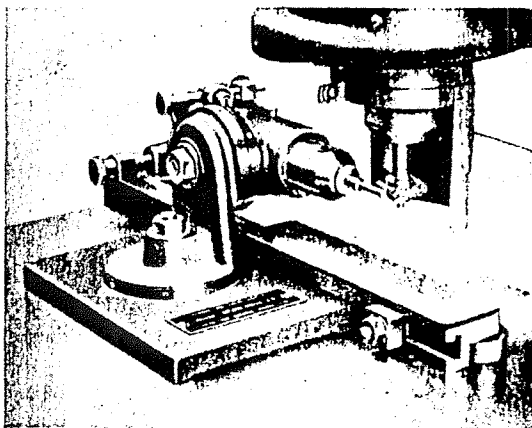
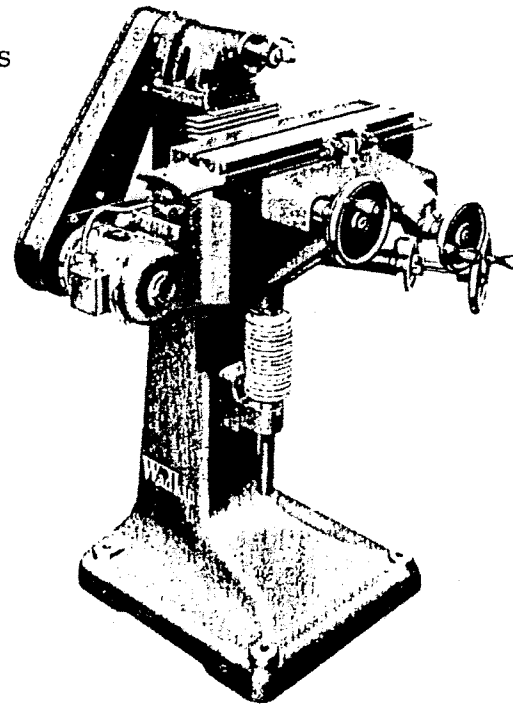

Whilst we strongly recommend the use of a separate grinder, where the number of cutters to be maintained does not justify either of the above machines, we can supply the fixture shown left for use on the Router itself. In this case it is essential to use the Router with speed 18,000 r.p.m., this lower speed being necessary for the grinding wheels.

INSTRUCTIONS FOR GRINDING WADKIN ROUTER CUTTERS

A sharp and properly ground cutter is the key to good routing. It is important, therefore, that the operator should understand exactly what he is doing when sharpening cutters.

Detailed instructions in the grinding of all types of router cutters are given on the following pages, and if read carefully and the instructions carried out will ensure trouble free running and high production.

WOODWORKING CUTTERS.

CHOICE OF THE CORRECT CUTTER.

In order to get the best results from routing it is essential to use the proper cutter for each operation. Straight cutters from 1/16" diameter to 1 1/2" diameter are available in varying lengths. A wide range of shaped cutters can be supplied, also built-up cutters for tonguing and grooving, moulding, etc., circular cutterblocks and moulding blocks. Illustrations show some of the principal types in the range.

TYPE 52
Panel
Cutter
Head

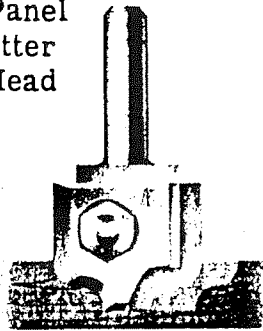

TYPE 53
Tonguing
and
Grooving
Arbor

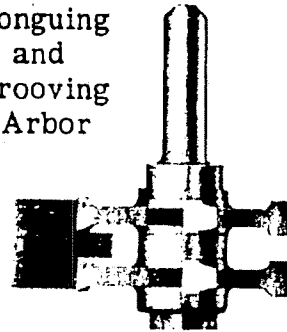

TYPE 1
Spoon Bit



TYPE 4
Double edge
Panel Bit



TYPE 21
Solid Profile
Cutter



TYPE 55
Circular Block



When in doubt, always consult Wadkin Ltd. for advice and recommendations. More information on cutter types can be obtained under the following References :-
Cutters for Wood, Plastics, Synthetic Bonded Ply. Book No. 713
Router operation, Design of Jigs and Fixtures, etc. Book No. 716

THE AIM OF CUTTER SHARPENING.

The primary object of cutter sharpening is to restore the cutting edge at the correct cutting angle and ensure correct clearance behind the cutting edge.

Relief or clearance.

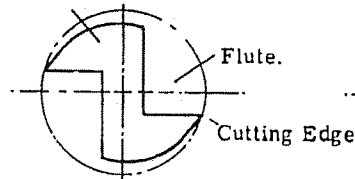

Correctly honed and ground cutter.

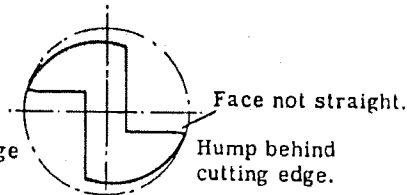

Incorrectly honed cutter.

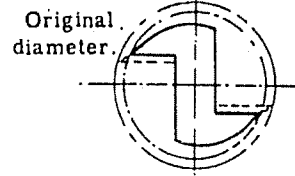

Worn cutter correctly ground and honed.

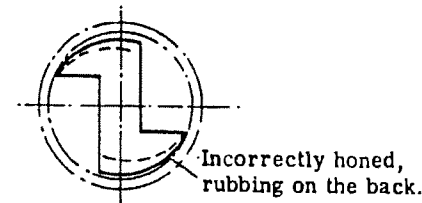

Dotted line indicates necessary grinding to restore cutting edges.

THE IMPORTANCE OF MACHINE GRINDING.

The key to high quality routing is a cutter with clean sharp edges and smooth continuous relief. In order to maintain the correct cutting angle and clearance, machine grinding is essential. Experience has shown that free-hand grinding does not give the clean smooth edge essential for good cutting, and the result is nothing like the life of a machine ground cutter. Another important point is that it is almost impossible to grind equal amounts from both edges free-hand. Mechanical grinding ensures that both edges of a cutter are identical, also the minimum amount of metal is removed at each regrind, thus making sure of longer life from a cutter than when most carefully free-hand ground.

GRINDING MACHINE, TYPE N. U.

This is the Grinding Machine generally supplied for grinding router cutters (see illustration on Page 42). It has a spindle speed of 4,750 r. p. m. and is provided with rise and fall, and also traverse movement to the table. With the aid of the three attachments shown overleaf, most types of cutters for both metal and wood routing can be dealt with. The class of work being done will dictate the attachments needed, but for wood cutters the S. F. A. attachment is essential, and the P. R. F. is very useful for regrinding the relief on straight panel cutters. For sheet dural, alclad and brass the D. G. A. and P. R. F. attachments are essential.

Where an existing Tool Room Grinder of suitable type and having a speed of not less than 5000 r. p. m. is available, the grinding attachments only are needed.

In such cases the user would need to make a spindle extension arbor to suit his machine.

GRINDING ATTACHMENTS

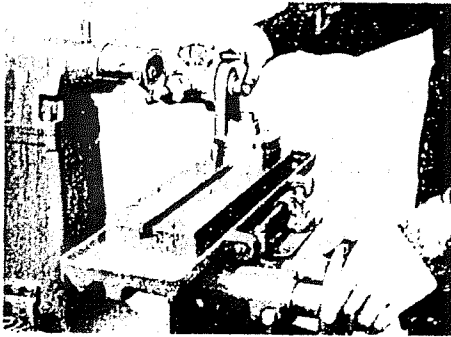

ATTACHMENT S. F. A.

to be used for grinding straight fluted cutters of all types, also ending up panel cutters and Spoon Bits.

This attachment will generally be used for profiling cutters and spoon bits. It is also suitable for tungsten carbide cutters.

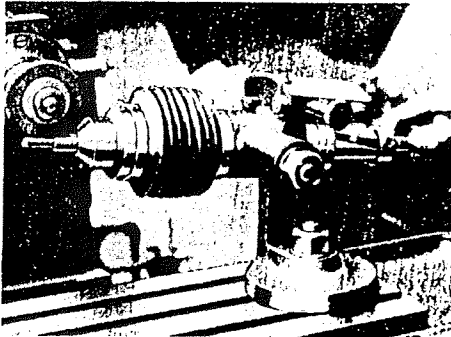

ATTACHMENT D. G. A.

to be used for grinding the flutes (spiral or straight) of all alclad or dural cutters used on SHEET WORK.

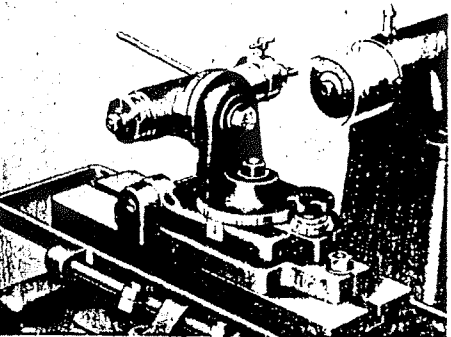

ATTACHMENT P. R. F.

to be used for regrinding the eccentric relief on panel cutters; suitable for dural, alclad and brass cutters, after loss of clearance due to continuous honing.

Grinding wheels supplied with GRINDING ATTACHMENTS.

FOR ATTACHMENT S. F. A. ONLY

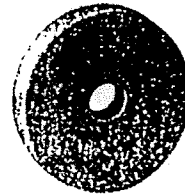

139

2" diameter
 $\frac{3}{8}$ " FLAT face
 $\frac{3}{8}$ " Bore

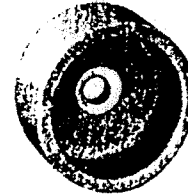

140

$2\frac{1}{4}$ " diameter
1" CUP
 $\frac{1}{8}$ " Bore

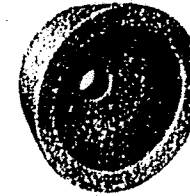

141

$2\frac{1}{4}$ " diameter
1" DISH
 $\frac{3}{8}$ " Bore

FOR ATTACHMENT D. G. A. and S. F. A.

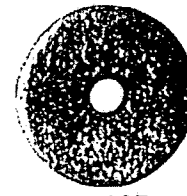

137

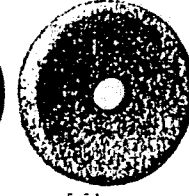

138

137
2" diameter
 $\frac{3}{16}$ " ROUND edge
 $\frac{3}{8}$ " Bore

138
2" diameter
 $\frac{1}{4}$ " ROUND edge
 $\frac{3}{8}$ " Bore

FOR ATTACHMENT S. F. A.

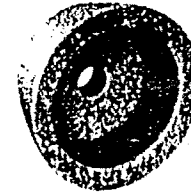

86R Rougher 87R Finisher

These wheels are used for grinding chipped edges of Tungsten Carbide Cutters. Both are $2\frac{1}{4}$ " diameter, 1" dish, $\frac{3}{8}$ " bore.

FOR ATTACHMENT P. R. F.

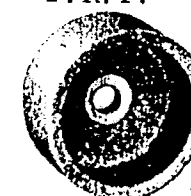

146

$2\frac{1}{4}$ " diameter
1" CUP
 $\frac{3}{8}$ " Bore

LAPS FOR TUNGSTEN CARBIDE
TIPPED ROUTER CUTTERS.



145

Diamond lap wheel for use on Attachment S. F. A. and used for lap finishing Tungsten Carbide Tipped Cutters after regrinding with wheels 86R and 87R.

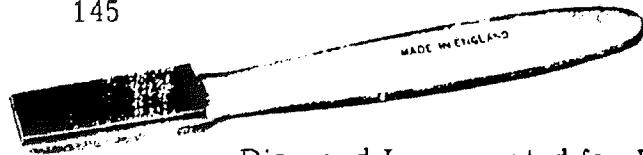

Diamond Impregnated for Hand Lap honing Tungsten Carbide Tipped Cutters. Also a similar hone of solid material in fine and medium grain can be supplied.

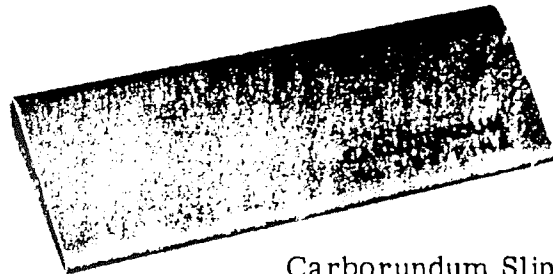

Carborundum Slip Stones
for High Speed Steel Router Cutters
No. 183. $4\frac{1}{2}'' \times 1\frac{3}{4}'' \times \frac{1}{2}'' - 3/16''$
No. 177. $4\frac{1}{2}'' \times 1\frac{3}{4}'' \times \frac{1}{4}'' - 1/16''$

WHEEL DRESSER DIAMOND PART NO. P. R. F. 37.

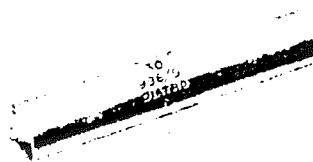

used for dressing all types of grinding wheels, excepting the Diamond Lap Wheel, No. 145.

REGRINDING STRAIGHT FLUTED CUTTERS OF
ALL TYPES, ON ATTACHMENT S. F. A.

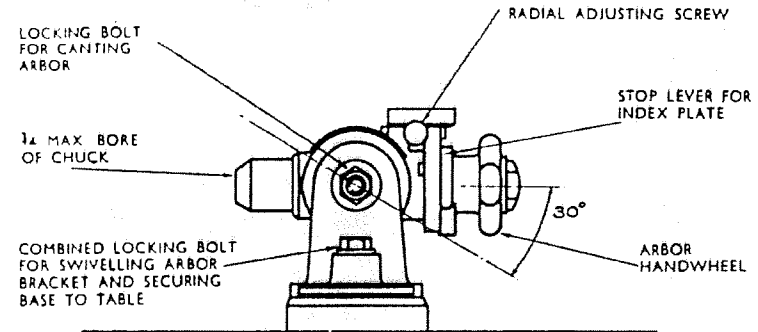

TYPES OF CUTTERS MOST COMMONLY GROUND
ON THIS ATTACHMENT :-

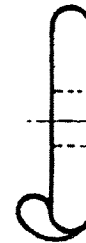

SPOON BITS. Use grinding wheels Nos. 137 and 138.

After grinding the flute, it will be necessary to stone a flat on the cutting edge of this type of cutter to obtain more clearance. The outside diameter should not be ground.

PANEL ROUTER CUTTERS
OR

SOLID SHAPED CUTTERS

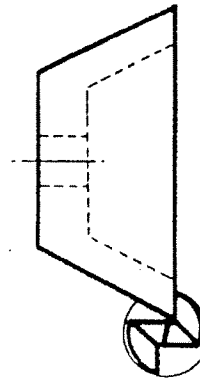

Use grinding wheels Nos. 140 and 141. After setting up as described opposite both flutes should be ground at the one setting.

After several regrinds of the flutes it becomes necessary on this type of cutter to give more clearance on the back of the cutting edge. (See pages 48 and 49.)

TO SET UP FOR GRINDING FLUTES.

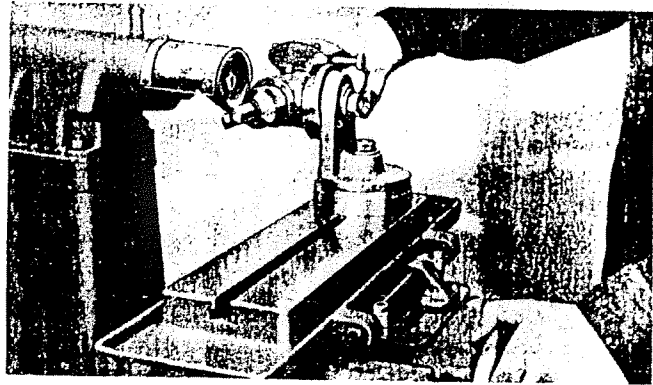

First bring the cutter flute into correct relation with wheel. Adjust the stop on machine table to suit length of flute to be ground. Use table movement to grind the flute taking light cuts. To put on any cut use the radial adjusting screw, thus maintaining a correct cutting angle. Both flutes should be ground after each adjustment to ensure that each is ground identically.

TO SET UP FOR GRINDING THE END OF THE CUTTER.

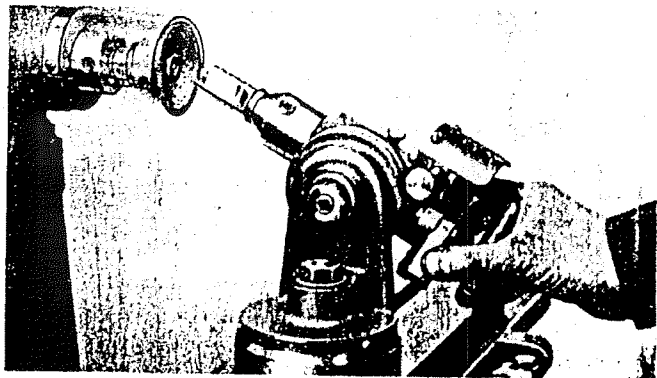

First turn attachment round at right angles to grinding wheel and lock up. Bring cutter into correct relation with wheel and adjust stop. Take light cuts by using table movement. The remaining face can be brought into a similar position by using index plate.

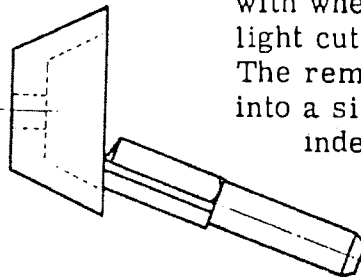

Use grinding wheels 140 and 141.

PERIPHERAL RELIEVING OR REGRINDING CLEARANCE OF PANEL CUTTERS ON ATTACHMENT S. F. A.

The best results on relief grinding are obtained by using the attachment P. R. F., as described on pages 49 to 53.

This method is illustrated for operators who have the S. F. A. Attachment only, but it should be stressed that the results obtained will not be as good as with the P. R. F.

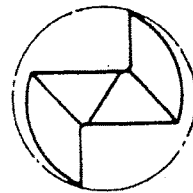

Fig. 1
Shows a new panel cutter with plenty of clearance.

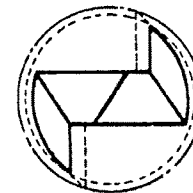
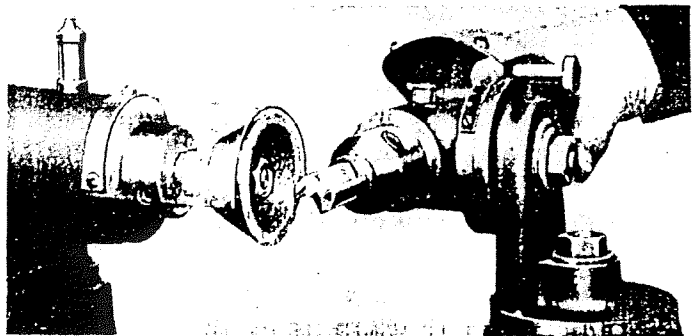

Fig. 2
Shows the same cutter after several regrinds with no clearance.

PERIPHERAL RELIEVING ON ATTACHMENT S. F. A.



Cutter is moved across the wheel by table movement as for grinding the flutes. Take light cuts.

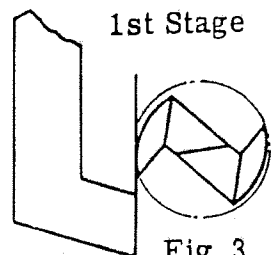

Fig. 3

Use wheel No. 140 or 141

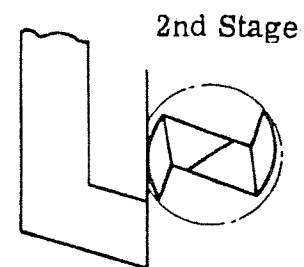
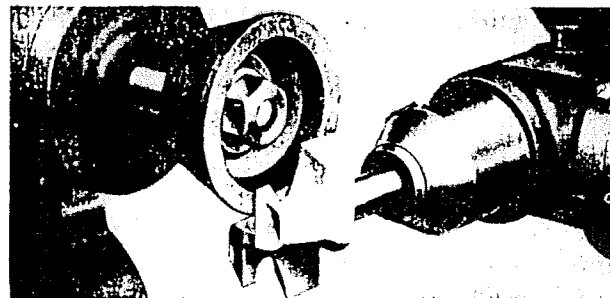

Fig. 4

Using same wheel.

GRINDING OF SHAPED CUTTERS TYPE NOS. 9, 11, 12, 32.

Shaped cutters must only be ground in the flute and must never be ground on the straight relief, unless the shape or profile of the cutter is being altered. This operation is done on the S. F. A. Attachment, using wheel No. 141. The method is illustrated right and described on page 48.



PERIPHERAL RELIEVING OF PANEL CUTTERS ON ATTACHMENT P. R. F., ALSO SUITABLE FOR RELIEVING OF TWO-EDGED CUTTERS FOR SHEET DURAL, ALCLAD AND BRASS.

This Attachment, mounted on our N. U. Grinder has been designed to obviate the poor results obtained when operating Routing Machines due to the outside relief of cutters being improperly honed, and in some cases, hand ground. It consists of a base plate, on which is pivoted a platen carrying a swivelling bracket, on which in turn is carried the spindle head which can also swivel. Both the swivelling units are graduated and the control knob for pivoting has also a graduated dial. The work spindle is on the eccentric principle, provision being made to vary the eccentricity (or radius of relief).

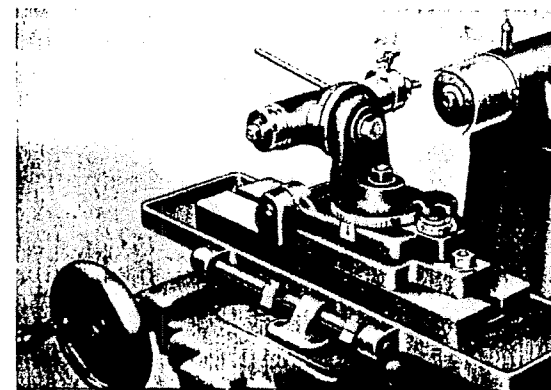

GRINDING OF GROOVING CUTTERS TYPES 41 - 53.

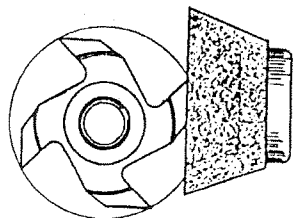

These cutters must never be ground in the flutes because of the loss of width which would quickly result, due to side relief of cutting edges. Resharpen these cutters by grinding on the outside face, using the S. F. A. Attachment.

Grinding of cutters for Flat Knife Chuck No. 50, Expanding Cutterhead No. 51, Panel Cutterhead No. 52, Circular Block No. 55.

For resharpening these cutters it is recommended that the knives be removed from the block and ground freehand on a moulding iron grinder.

For holding the cutters, bushes $\frac{3}{8}$ " and $\frac{1}{2}$ " bore are provided; these have two lines engraved at 180° , each line in turn being brought into alignment with a zero line on the spindle nose, thus enabling both edges of the cutter to be ground at one setting. An approximate position to place the cutter radially is also indicated by another line on the nose of each bush, one of the cutter edges being placed opposite this; this position can only be approximate as some cutters require more drastic relief (or clearance) than others.

This variation of clearance must not be confused with varying eccentricity or (radius of relief). The bushes are gripped in a split body and can be changed quickly.

A holder with diamond for trueing the wheel is also provided and fits the spindle nose the same as the cutter bushes. Arrangements are made to hold the work spindle radially when using the diamond. Part No. of this diamond is P. R. F. 37.

It is absolutely essential to true the grinding wheel with a diamond. A special fine grain wheel No. 146 is supplied with this attachment.

TO SET UP FOR GRINDING.

First set both swivelling bracket and spindle head with graduations at zero; then, with the vertical movement of the machine table, bring the attachment spindle to the same height approximately as the grinding wheel spindle (if anything the centre of the attachment spindle should be a little higher than the centre of grinding wheel spindle). Now insert cutter with one edge opposite the line on the NOSE of the cutter bush and tighten firmly with the set screw; then set cutter bush with one graduation in line with zero line on spindle nose and tighten with tee headed screw shown in right hand in Fig. 2. Fig. 3 shows cutter setting line on nose of bush and also one of the bush setting lines correctly set on the zero line of spindle nose; this photograph also shows the actual grinding operation.

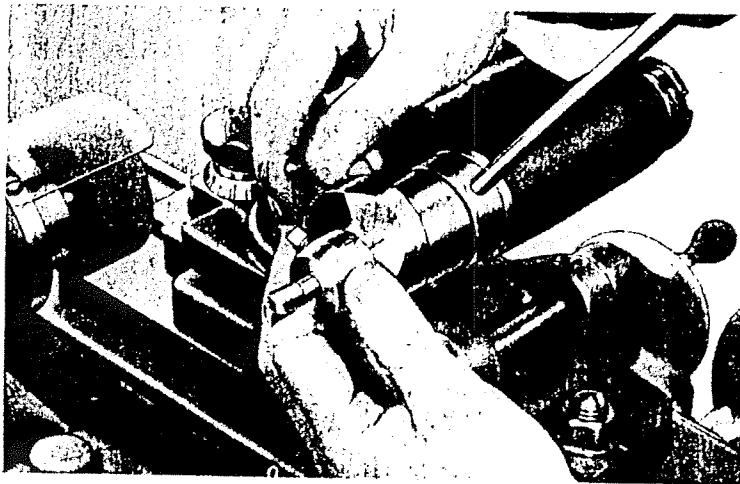

Fig. 2

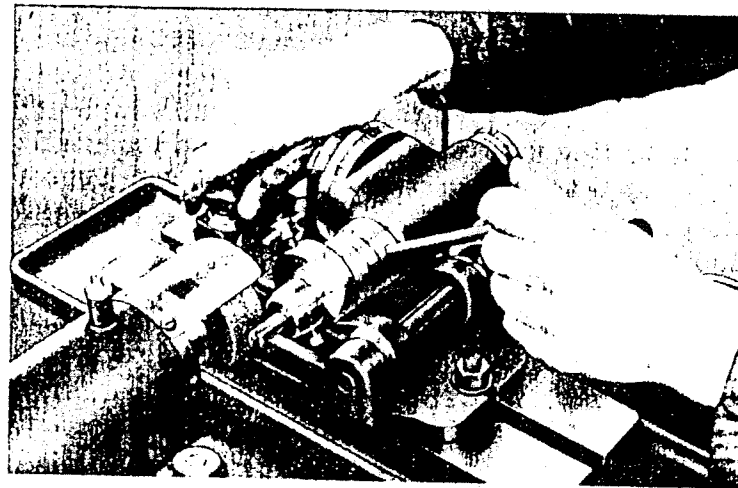

Fig. 3

It will not be necessary as a general rule to move the spindle head away from zero, but the swivelling bracket (which has its base on the platen) will require moving a little off zero for the spiral fluted cutters, otherwise, due to the spiral angle, the grinding operation will produce a taper cutter.

For right hand spiral cutters move the bracket zero line a little to the left and vice versa for left hand spiral cutter. Fig. 4 shows the zero line on bracket moved out of line as required for a right hand spiral cutter.

TO GRIND A CUTTER.

Unscrew control knob shown in right hand on Fig. 4 to give about $\frac{3}{8}$ " opening between the platen and base plate. Bring the table up until the surface of the cutter to be ground is $\frac{1}{16}$ " away from the grinding wheel; then move table stop indicated by left hand up to stop bracket and tighten up.

Start machine, and by the control lever rotate one edge of the cutter to and fro, bringing the cutter into contact with the grinding wheel by turning the control knob clockwise.

Take care not to take the control lever too far over or the opposite cutting edge will come into contact with the wheel and be damaged.

Now bring the table and fixture away from the wheel and note the number of the graduation on the control knob dial which is opposite the zero line on the platen.

Unscrew control knob half to three quarters of a turn, unscrew tee headed screw shown in right hand on Fig. 2 and turn cutter holder round until the arrow on opposite side is in line with zero mark on spindle nose; left hand indicates this being done (do not release cutter), then tighten up tee headed screw, move table up to stop and proceed as before until dial on control knob comes to the same number as before. For metal routing cutters proceed to remove a further .010", to cut back one edge, by using in feed of machine table. See Page 57.

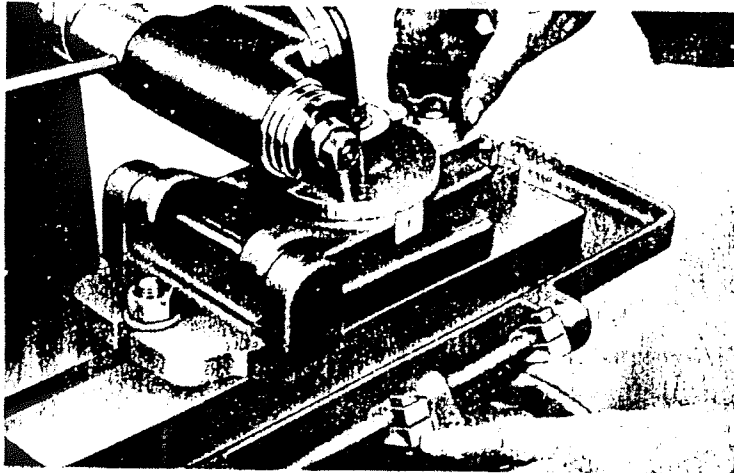

Fig. 4

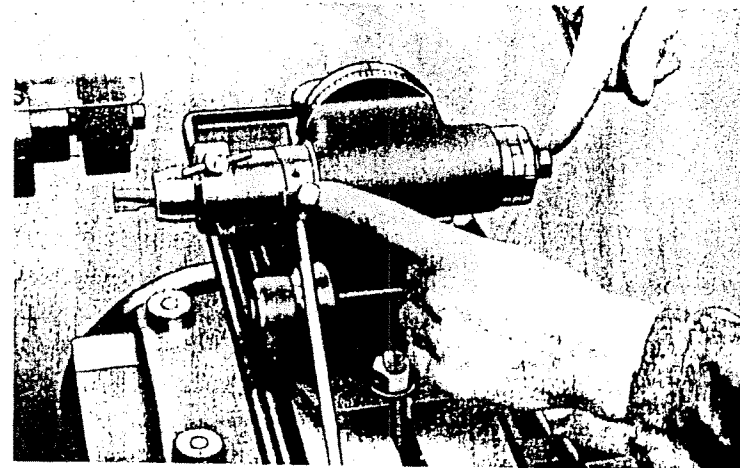

Fig. 5

For cutters of greater length than the face of the wheel, repeat the operation with the table cross traverse adjusted to cover the remaining length of the cutter edge. When finishing, pass the cutter over the grinding wheel once or twice, moving the cross traverse slide sufficiently to cover the whole length of the cutting edge being relieved. On short cutters move the cross traverse a little each way to improve the surface finish.

Fig. 5 shows how the eccentricity (or radius of relief) is varied.

The spindle nose has an initial amount of eccentricity which can be varied as follows :-

Ease hexagon nut indicated by right hand, but do not slacken it right off; slacken off the small screw indicated by left hand, say a quarter of a turn, and tighten the one on the opposite side; this increases the eccentricity. To decrease the eccentricity slacken the screw on the opposite side and tighten the one indicated by left hand; then re-tighten the nut indicated by right hand. On no account try to adjust without easing the hexagon nut and be sure to re-tighten.

The amount of eccentricity required and the exact position to set the cutter are dependent on conditions and must be left to the operator who will find these adjustments quite easy after a little experience.

Fig. 6 shows the split chuck and the simplicity of changing cutter bushes or inserting the diamond holder. All that is necessary is to release the tee headed screw and draw the bush out; insert another, pushing it right up to the shoulder; bring the graduated line opposite zero line on the spindle nose and re-tighten the tee headed screw.

See that bushes and the base of the split chuck are perfectly clean and free from grit.

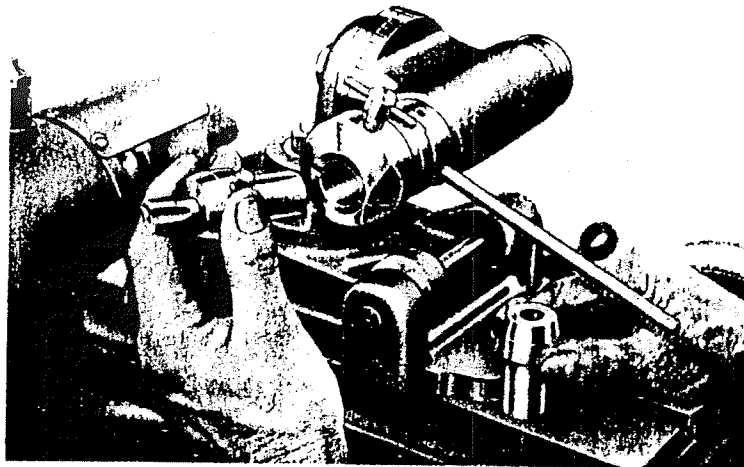

Fig. 6

TO DRESS THE WHEEL.

Fix clip onto operating handle as shown by right hand in Fig. 7, then insert the diamond holder in the spindle nose with the diamond inclined to point a little below centre (this is important) and follow the same procedure as for grinding cutters (see Page 51), using the cross slide of machine to pass the diamond across the periphery of the wheel and the control knob to regulate the cut as shown in Fig. 8.

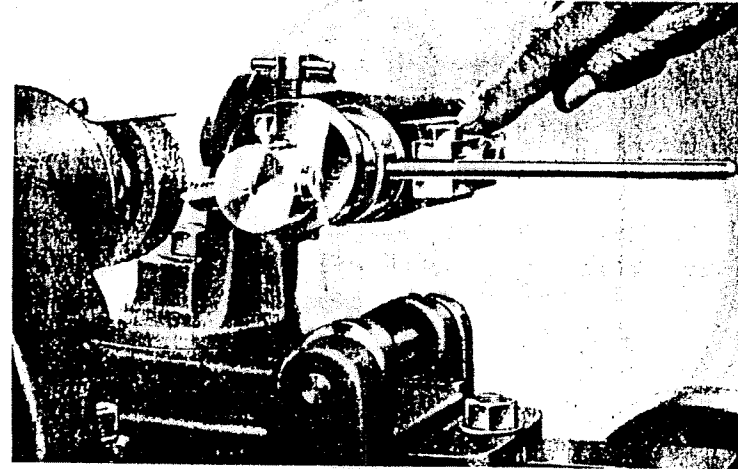

Fig. 7

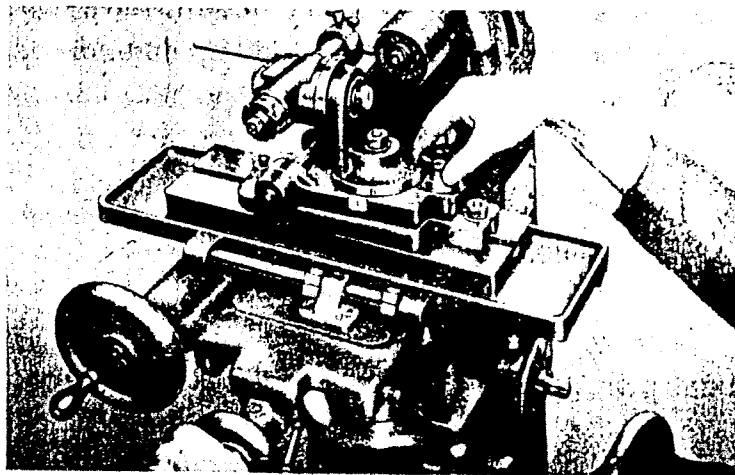
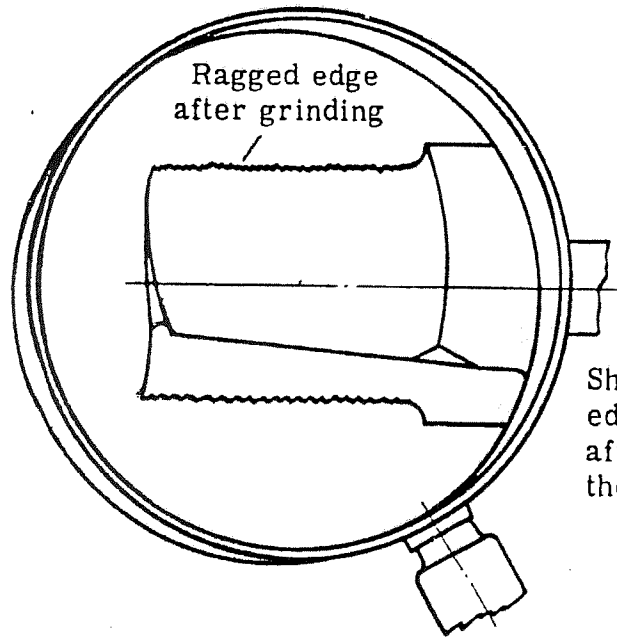

Fig. 8

See that the table stop is tight, only take **LIGHT** cuts and pass the diamond over the wheel slowly and with a continuous regular motion. When mounting the wheel on machine spindle place it with the recessed side towards the machine as shown in Fig. 2.

Frequent dressing of the grinding wheel is not necessary. Considerable quantities of cutters should be ground between dressings and after the initial truing of a new wheel subsequent dressings should be of the lightest character.

STONING OF CUTTERS



Shows ragged edge of cutter after grinding the flutes.

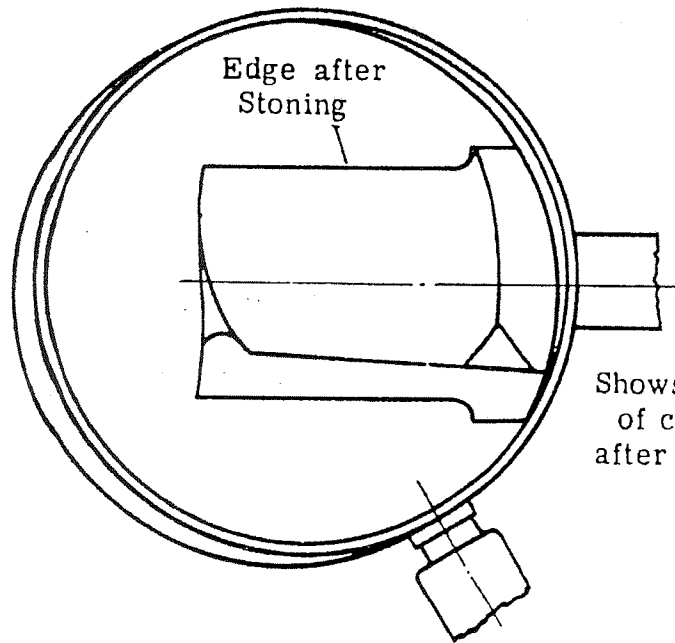

Shows edge of cutter after Stoning.

THE RIGHT AND WRONG WAY OF STONING

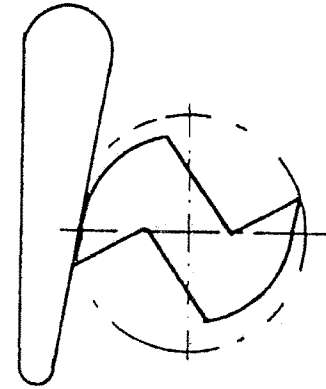

THE RIGHT WAY - Cutting edge is on the outside periphery of cutter track, with back of cutter clearing the job.

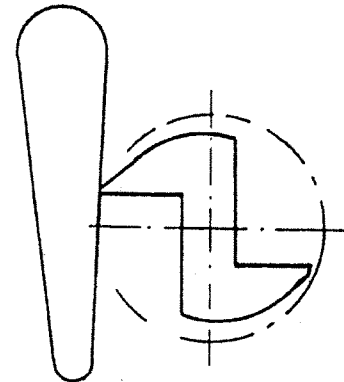

THE WRONG WAY - Back of cutter forms outside periphery of cutter, with the result that rubbing of the back on the job occurs.

STONING OF CUTTERS

After grinding, the cutter must be stoned up before using to remove the ragged edge. This is done by using a No. 183 or 177 Carborundum slip stone dipped in paraffin and applied to the edge of the cutter as shown below. (Stones are illustrated on Page 47). Correct stoning can only be achieved by practice, but most operators have no difficulty with this operation after a few weeks experience. A reliable guide as to whether the cutter has been properly stoned will be that the job will almost feed itself, instead of requiring force in feeding past the cutter. In addition to stoning after grinding, the cutter will need restoning between regrinds. The length of time the cutter will retain its edge will depend on the material, and may vary between half an hour and two hours or more. Here again, the effort required to feed the work is the best indication of the condition of the cutter and whether stoning is required. Stoning for half a minute should be sufficient and the cutter should stand between four and eight restonings between regrinds, depending on the skill of the operator.



TYPICAL QUESTIONS AND ANSWERS ON WOOD ROUTER CUTTER SHARPENING.

Is a cutter as despatched by the makers ready for use?

No. It requires honing or stoning before being used. The cutters are sent out as they leave the Grinding Machine. They are not stoned up at our Works as the edge may be damaged in transit.

Is the use of a slip stone necessary on router cutters?

Yes. All cutters should be honed before using on the Router. The sharper the cutter the better the finish and the faster the feed.

What sort of slip stone should be used, and what methods should be employed?

See recommendations as regards stones on Page 47, and the method of stoning, Pages 54-55.

How often should the cutter be honed?

This depends on the timber being cut. Stringy timber may require a stone on the cutter every 20 minutes, while on clean straight grain wood the cutter may run for an hour.

When does a cutter need sharpening?

When the work is difficult to push past the cutter, or when the finish is not clean and smooth, the two characteristics generally go together. When the cutter is sharp, the work will almost feed itself.

What determines whether a panel cutter should be ground in the flute or on the relief?

The general practice is to grind in the flute, as shown on Page 48, and continue to do so until the relief or clearance, shown on Page 44, becomes insufficient. Then regrind the relief as shown on Pages 49 to 52.

Is there any means of truing the emery wheels on the Cutter Grinder?

Yes. The diamond mounted in a steel holder, $\frac{1}{2}$ " diameter, is shown on Page 47. The method for truing wheel No. 146 is shown on Page 53. When truing the face of the wheel No. 141, mount the diamond in place of the cutter on the attachment S. F. A. shown centre of Page 48, and proceed as described on Page 53.

Is machine grinding of cutters essential?

Yes. To get good work, and economy of cutter life. See Page 45.

ROUTER CUTTERS FOR NON-FERROUS METALS.

CUTTERS FOR NON-FERROUS SHEETS.

Wadkin cutters are made in two ranges, one having a profile suitable for cutting Dural and Brass, and the other suitable for cutting Aluminium and Alclad. In general, these cutters are quite suitable for use as sent out, without modification of the profile, but some operators claim to obtain improved performance by slightly modifying the profile of the cutter to suit the particular specification of metal which they are cutting.

These modifications may be regarded as refinements and should not be attempted until the operator has become quite proficient in the use of the machine.

The types of cutters available are shown on a list which is issued and revised from time to time, and can be obtained on enquiry from us. All Wadkin cutters are numbered and it is advisable to quote the reference number when ordering or referring to specific types and sizes of cutters.

For cutting out from sheet the best size to use is a $\frac{3}{8}$ " diameter double-edged cutter, having a $\frac{1}{2}$ " diameter shank. It is possible to use a $\frac{1}{4}$ " cutter where $\frac{1}{8}$ " internal radii are essential or $\frac{1}{2}$ " diameter, if required.

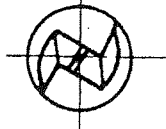

Typical cutter for profiling.

CUTTERS FOR PROFILING CASTINGS STAMPINGS AND NON-FERROUS METAL FACED PLYWOOD, ETC.

For this class of work we recommend an entirely different range of cutters from those used for sheet cutting. In general, these cutters are Z section with straight flutes, but it is advisable to consult us before ordering cutters, to ensure that the most suitable type is used for the particular metal to be cut and for the amount of metal to be removed.

SIZES OF CUTTER SHANKS.

All cutter shanks on the cutters we supply are held to a limit of $+.0005$ and $-.0005$ ", i. e. a tolerance of one thousandth of an inch, but whatever the diameter it is most important that the shank is parallel. A cutter shank over $.0005$ " taper will not give satisfactory results.

SMALL CUTTERS FOR SPECIAL WORK SUCH AS GROOVING.

When using small cutters, such as $\frac{1}{8}$ " or $\frac{3}{16}$ " diameter, we recommend ordinary wood cutting spoon bits, and these are quite satisfactory. Always shorten the cutting blade as much as possible to avoid breakage. This is best done by the user himself as the cutters can then be shortened to suit his own type of work.

REGRINDING STRAIGHT OR SPIRAL FLUTED CUTTERS FOR NON-FERROUS METAL SHEETWORK ON

ATTACHMENT D. G. A.

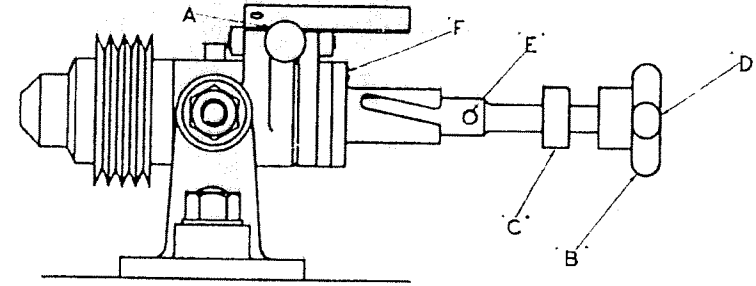

TO SET UP FOR GRINDING STRAIGHT FLUTES.

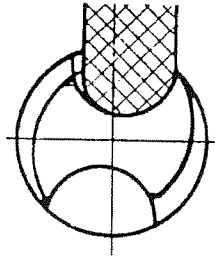

Use grinding wheels Nos. 137 or 138.

The cutter is placed in the spindle nose and the attachment adjusted to bring the flute into correct relation with the wheel, i e. , parallel with the table slots. The table and cross slide should then be locked, and the rise and fall of the table and the radial adjustment screw "A" only, should be used during the subsequent grinding operation.

The cross slide of the table must not be used to put on cut after once setting up, as this will alter the contour of the flute, thus varying the cutting angle.

TO SET UP FOR GRINDING SPIRAL FLUTES ON METAL CUTTERS.

The set up and method of grinding in this case is identical with that for the straight fluted cutters except that it is necessary to set over the head as shown below to bring the flute into the correct parallel relation with the table slots.

It will also be necessary to change the slotted sleeve. To do this first remove the handwheel B and collar C by loosening grub screws with the special key provided. Slacken off grub screw D in the end of the spindle and withdraw guide pin E. Unscrew the three countersunk screws F from the sleeve. The sleeve is now free to be withdrawn from the spindle.

PLAN VIEW SHOWING HEAD SET OVER FOR GRINDING SPIRAL FLUTES.

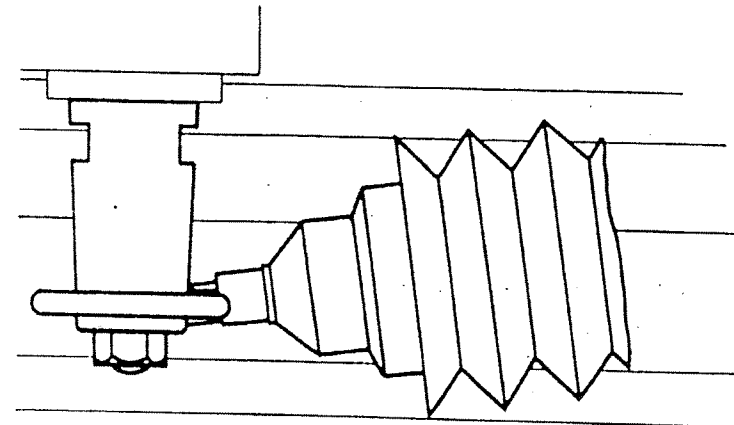

METHOD OF GRINDING FLUTES ON THE ATTACHMENT D. G. A.

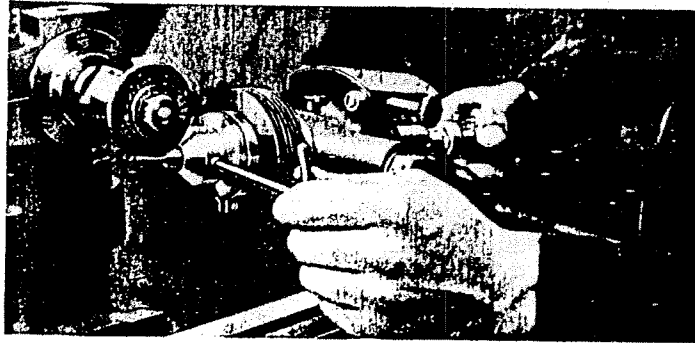

- 1 Bring the cutter into the correct relation with the grinding wheel by adjusting the table slides. Lock table slides and lock cutter as shown above.

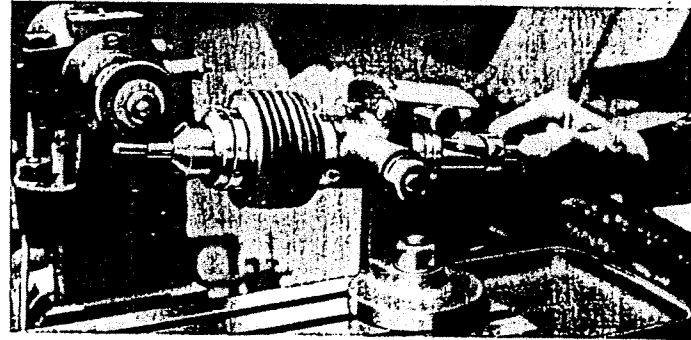

- 2 The grinding is done by sliding the cutter past the wheel, taking care to set the stop collar near the operating handle. This motion is controlled by a grooved sleeve. Raise the table until the wheel makes contact, and draw spindle right back after making each stroke. Turn through 180° , then grind the other flute.

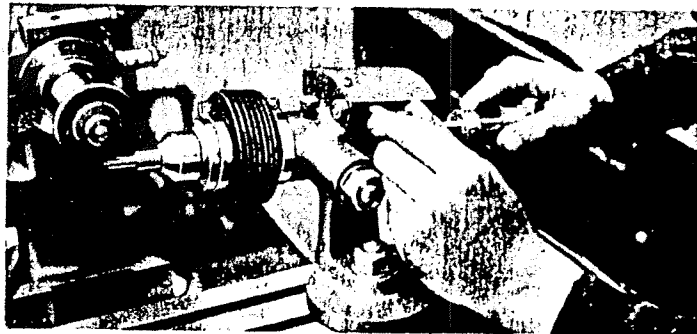

- 3 The cutting edge of the cutter is adjusted relative to the grinding wheel by turning the small screw as shown above. Both flutes should be ground at the one setting. If after examination both edges have not been cleaned up, put on more radial cut and repeat the grinding operation. Both flutes should be ground after each adjustment to ensure that both flutes are ground identically.

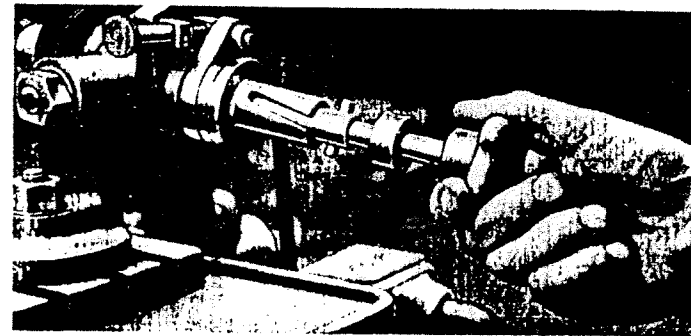

- 4 After grinding one flute of the cutter, the spindle is drawn back to bring the diagonal pin clear of the bush, as shown below. It is then rotated half a turn to bring the opposite flute into position, when the pin can be re-inserted in the bush.

TYPICAL QUESTIONS AND ANSWERS ON METAL CUTTER SHARPENING.

Is a cutter received from the Stores ready for use?

No. It requires honing or stoning before use. The cutters are sent out as they leave the Grinding Machine. They are not stoned up at our Works, as the cutting edges would be damaged in transit.

Is it permissible to use an oil stone on the outside of the cutters when dull?

This is the essence of routing and the key to high performance. As soon as the cutter begins to drag, stop the machine and hone up the cutter on the outer edges until they are sharp. This can easily be done in half a minute and the method is illustrated on pages 54 and 55.

How often should a metal working cutter be stoned?

About every hour. On hard material it may be every half hour. On some soft materials every two hours, but on aluminium and alclad sheets it pays to keep the cutter sharp to prevent packing on the cutter.

How many times should a cutter be stoned between regrinds?

A cutter should stand four to eight stonings depending on the skill of the operator.

What stone should be used and should it be used dry?

A No. 183 Carborundum Slip Stone. Dip the stone in oil and paraffin to give the best results.

Should the cutters be used dry on metal?

No. Always use a lubricant consisting of paraffin and lard oil, mixed and applied to the sheets by brush before commencing to cut. The paraffin is only a thinner to help to spread the lard oil, and only enough for the purpose should be used. Excessive paraffin causes a blue smoke when cutting.

What causes metal chips to pack on the cutter?

Generally, blunt cutters. The wrong shape of cutter, especially on aluminium and alclad sheets will cause it, also a lack of lubricant.

What causes chips to pack in the guide bush?

Blunt cutters. They make shreds of swarf which work up into the bush and weld to the shank. If the cutter is correct the large curly chips cannot possibly get into the small clearance between cutter and guide bush.

What causes shudder when cutting?

The cutter has not been stoned. The rough saw edge left by the grinding wheel causes it. To cure it, stone the cutter.

TYPICAL QUESTIONS AND ANSWERS - Continued.

Can the loss of diameter due to cutter wear be compensated for?

Yes. All Fixed Head Routing Machines are now sent out with a range of graded pins :- .005", .010", .015", .020" on all sizes. On the Radial Machine, undersized guide bushes can be supplied.

What is the feed speed on the Router?

Feed as fast as the cutter will take it. If the cutter is sharp the job will almost feed itself and will only require guiding. If the job needs pushing the cutter is not sharp. On metal, a good speed on straight work is 4 inches per second. On intricate shapes, it is impossible to feed at this speed, and the limitation is the speed at which the operator can manipulate the job, generally, 1 to 2 inches per second.

Can sheet steel be routed?

No, only non-ferrous metals such as Alclad, Dural, Aluminium, Brass, Copper, Lead. Not Bronzes, Zincs or Tin.

TUNGSTEN CARBIDE TIPPED ROUTER CUTTERS.

As a general rule, tungsten carbide cutters should only be used when high speed steel cutters will not stand up to the hardness of the material being routed. They are not suitable for ordinary timbers and will not cut half as cleanly as high speed steel on wood.

Tungsten carbide cutters are necessary on the following materials :-

Resin bonded plywoods, wood pulped board and wall board, plastics such as Holloplast and Catalin. Linen and paper based materials, such as Tufnol and Elephantide. Aluminium alloys, die cast or wrought, containing silicon or manganese (there are certain high silicon alloys which are too hard even for tungsten carbide on the router). All sand cast aluminium castings.

Type 60, Two Edged Panel Cutter, for cutting outside profiles only. Not suitable for sinking or cutting inside profiles.

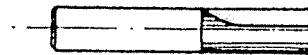

Dia. $\frac{3}{8}$ " $\frac{1}{2}$ " $\frac{1}{2}$ "
 Length on cut $\frac{3}{4}$ " $\frac{3}{4}$ " $1\frac{1}{4}$ "

Type 61, Two edged Panel Cutter, for sinking and cutting on side.



Dia. $\frac{3}{8}$ " $\frac{1}{2}$ " $\frac{5}{8}$ " $\frac{3}{4}$ "
 Length on cut $\frac{3}{4}$ " 1" $1\frac{1}{4}$ " $1\frac{1}{4}$ "

Type 62, Single Edge Spoon Bit, suitable for sinking and cutting on side.

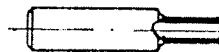

Diameter $\frac{3}{8}$ "
 Length on cut $\frac{3}{8}$ "

Other sizes and profile cutters of all types are available to special order.

SHARPENING TUNGSTEN CARBIDE ROUTER CUTTERS.

Tungsten carbide cutters cannot be sharpened with ordinary grinding wheels or honed with Carborundum honing stones. The grinding can be done on the N. U. Grinder and S. F. A. Attachment described on pages 45-46, using grinding wheels 86R and 87R described on page 46. Use the wheels dry; 86R for roughing, taking very light cuts, and expect to take a long time removing a small amount of carbide. Finish grind dry, using wheel 87R. In order to get a good cutting edge it is necessary to machine lap with wheel No. 145. This wheel is made from soft material and its cutting edge is impregnated with diamond dust. It is expensive to use and should be used for final finishing. It can, of course, be used for grinding in place of the 86R and 87R wheels, but the wear and cost of the laps would be prohibitive. Never attempt to true the diamond lap. When using the machine lap smear the face of the wheel with oil and then take the lightest possible cuts to get a polished face and a clean edge. Finish the cutting edge with a hand lap, which is also impregnated with diamond dust and is illustrated on page 47.

The best method of using the hand lap is to immerse the lap and tool under water and hone in this position. This is recommended so that the diamond dust freed from the lap floats to the surface of the water and does not become abrasive between the cutter and the lap, causing excessive wear on the lap. If this is not possible, use as much water as possible to swill off the diamond dust.

The general instructions on stoning cutters on pages 54-55 apply to tungsten carbide cutters except that the diamond lap is used instead of the Carborundum stone.

Tungsten carbide cutters sent out from our Works require honing with the hand lap.

CONCERNING CUTTER COLLETS.

Never over-tighten a collet. The short spanner or screw key provided is designed to give the maximum grip, when used by the average operator. The use of a pipe wrench strains the collet and actually reduces the grip on the cutter.

Never allow cutters to project from the collet more than is absolutely necessary. It is a golden rule that the nearer the cutter to the collet, the better the cut and the longer the life of the cutter.

WIRING DIAGRAM, ROUTER MODEL L.S. D. 1026/1.

SELECTOR SWITCH CONNECTIONS

- (1) 'LOW' CONNECTS 1 TO 2
5 TO 6
- (2) 'HIGH' CONNECTS 3 TO 4
7 TO 8

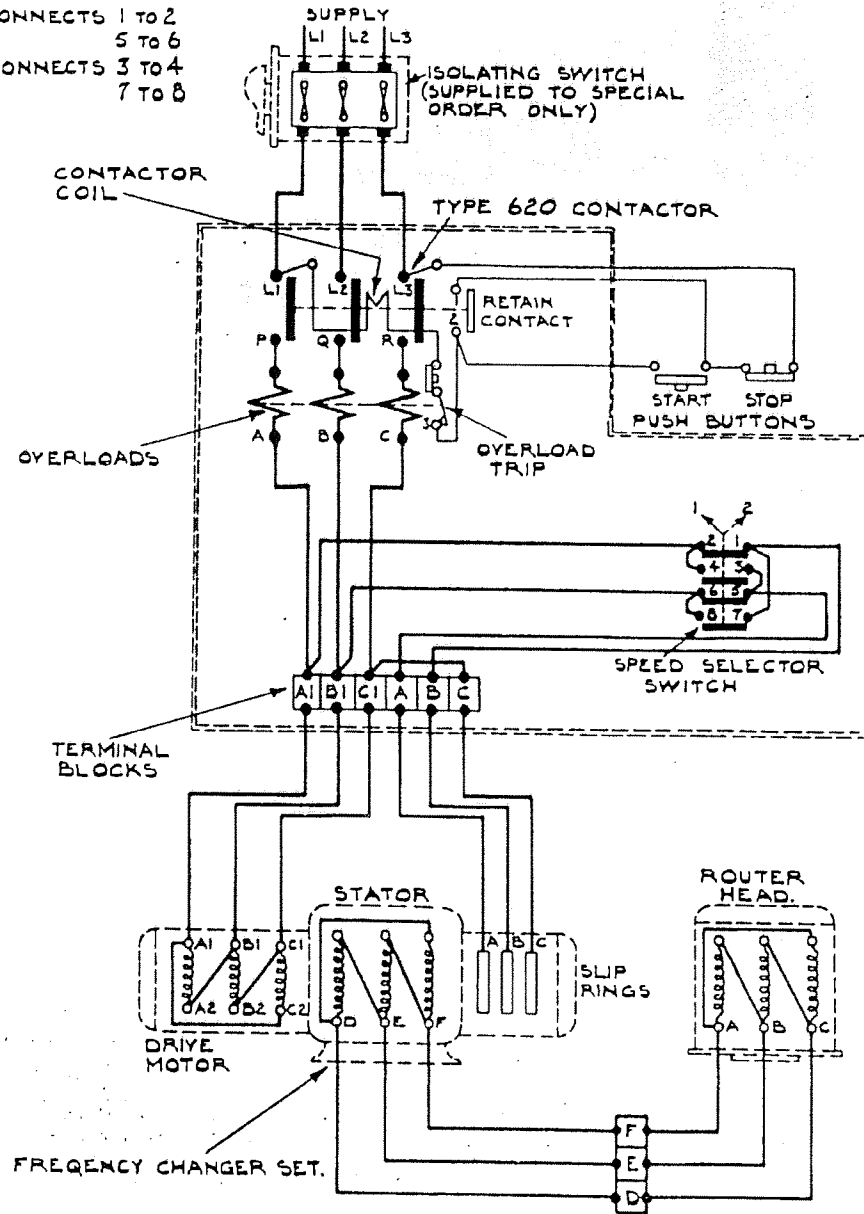

INSTALLATION INSTRUCTIONS

Fit isolating switch near machine so that the electrical gear may readily be isolated for inspection purposes. Bring supply cables to isolating switch and to L1-L2-L3 at contactor through conduit which should be screwed into the control gear box and secured by means of locknuts. Remake the following connections which are broken for transit, at terminal blocks in control gear box:- drive motor at terminals A1-B1-C1, slip rings at terminals A-B-C, connect router head to frequency changer terminals D-E-F.

Ensure that the direction of rotation is correct before putting the machine into service, to reverse rotation interchange L1 and L3 at contactor.

OPERATING INSTRUCTIONS

To start machine: close isolating switch and press "start" button. To stop machine: press "stop" button. To lock off machine: press and turn "stop" button, this must be released before a start can be made.

OVERLOAD

Should the machine stop due to overload wait for a short time to allow coils to cool, then start in the usual manner. The overloads are set at these works at "auto" for automatic reset after tripping, if set at "hand" the plunger on the overload assembly should be depressed to reset.



... blow away harmful dust, chips and dirt with a Wadkin Electric Blower

No motor can run at its maximum efficiency with its ventilating duct or control gear covered with dust and dirt. Sooner or later the resultant overheating will cause serious trouble.

Similarly, accumulations of chips and dust, in the mechanical parts of the machine can interfere with its efficiency. A few minutes a week for blowing down all Woodworking Machinery will be amply repaid in better and easier running, in increased life, and freedom from breakdown.

Blowers can be supplied for single phase A.C. or Direct Current for any voltage up to 250.

Please state voltage when ordering.





SPARE PARTS BOOKLET

CONTENTS

1. Basic ordering requirements.
2. Sample type order.
3. List of item numbers and description of item.
4. Drawing showing item numbers.

LSA

HIGH SPEED ROUTER

COMPOUND TABLE

SPARE PARTS

Should spare parts be required due to breakage or wear full particulars including the machine and test number must be given. This information is on the nameplate attached to the machine and will be similar to the picture below.

Wackin Ltd. LEICESTER ENGLAND		
MACHINE SERIAL NO.	FD 5134	
MACHINE TEST NO.	70601	
PATENT NO.		
VOLTAGE	PHASE	CYCLES
400	3	50
SEE MAINTENANCE INSTRUCTION BOOK FOR LUBRICATION DETAILS		

Please see the next page for sample detail of how to order spare parts.

SAMPLE TYPE ORDER

MACHINE: LSA ROUTER

MACHINE NO: 1407

TEST NO: 68975

PARTS REQUIRED

1	-	LS1077/LS11	Head Link
1	-	LS1077/LS18	Locking Ratchet Bracket
1	-	LS1077/LS74/B	Lower Lever
1	-	LS1077/LS468	Release Pedal Lever
1	-	LS1077/LS649	Foot Pedal

LS SPARE PARTS LIST

<u>ITEM NUMBER</u>	<u>DESCRIPTION</u>
LS1077/LQ51	INTERMEDIATE SLIDE
LS1077/LQ52	TABLE SLIDE
LS1077/LQ53/A	VERTICAL SLIDE
LS1077/LQ54	PLUNGER KNOB
LS1077/LQ55	BEARING FOR TABLE SCREW
LS1077/LQ57	PLUNGER BRACKET
LS1077/LQ58/A	PLUNGER LEVER
LS1077/LQ59	STOP BAR FOR BOTTOM SLIDE
LS1077/LQ82	TABLE STOP
LS1077/LQ83	LOCKING BOLT FOR STOP
LS1077/LQ84	STOP
LS1077/LQ85	PLUNGER STOP
LS1077/LQ86	COVER PLATE FOR PLUNGER
LS1077/LQ87	BOTTOM PLATE FOR PLUNGER
LS1077/LQ88	BUSH FOR PLUNGER
LS1077/LQ89	PINION FOR PLUNGER
LS1077/LQ90	PLUNGER
LS1077/LQ91	LOCATING PIN FOR PLUNGER
LS1077/LQ94	SPRING FOR PLUNGER
LS1077/LQ151	SHAFT FOR RAISING MITRE
LS1077/LQ152	FEED SCREW
LS1077/LQ153	WORMSHAFT
LS1077/LQ154	RACK FOR TABLE
LS1077/LQ155	SPIGOT FOR SLIDE
LS1077/LQ156	CLAMP PLATE
LS1077/LR32	NUT FOR TABLE SCREW
LS1077/LR151	WORM FOR TABLE RACK
LS1077/LR155	SLIDE STRIP BACK L/H
LS1077/LR156	SLIDE STRIP FRONT L/H
LS1077/LR157	SLIDE STRIP R/H

LS1077/LR158	WEAR STRIP
LS1077/LR162	TABLE LOCKING ROD
LS1077/LR163	TABLE LOCKING PAD
LS1077/LR164	SLIDE LOCKING ROD
LS1077/LR165	SLIDE LOCKING CAM
LS1077/LR166	SLIDE LOCKING PAD
LS1077/LS1/C	MAIN FRAME
LS1077/LS7	DEPTH STOP BASE
LS1077/LS8	DEPTH STOP QUADRANT
LS1077/LS9	NUT FOR RAISING SCREW
LS1077/LS11	HEAD LINK
LS1077/LS18	LOCKING RATCHET BRACKET
LS1077/LS74B	LOWER LEVER
LS1077/LS103	TABLE STOP
LS1077/LS104	WIDE STRIP FOR SLIDE
LS1077/LS105	NARROW STRIP FOR SLIDE
LS1077/LS106	WEAR STRIP FOR SLIDE
LS1077/LS107	LOCKING COLLAR FOR TABLE
LS1077/LS117	FULCRUM SHAFT FOR LOWER LEVER
LS1077/LS118	WASHER FOR LOWER FULCRUM SHAFT
LS1077/LS119	FULCRUM SHAFT FOR UPPER LEVER
LS1077/LS120	PIN FOR LEVER END AND HEAD LINK BRACKET
LS1077/LS121	BOTTOM ANCHORAGE FOR COUNTER BALANCE SPRING
LS1077/LS123	COUNTERBALANCE SPRING
LS1077/LS125	RETURN BUFFER FOR HEAD
LS1077/LS126	SCREW FOR MULTIPLE STOP
LS1077/LS128	HOLDOWN PIN FOR STOP QUADRANT
LS1077/LS131	STRIP FOR HEADSLIDE
LS1077/LS138A	RETURN STOP FOR HEAD
LS1077/LS139	NUT FOR CHUCK
LS1077/LS168	PEDAL LOCKING BRACKET
LS1077/LS169	PEDAL LOCKING PAWL

LS1077/LS170	STUD FOR RELEASE PEDAL
LS1077/LS288	PIN FOR LOWER LEVER
LS1077/LS367	TABLE RAISING SCREW
LS1077/LS361	PIN FOR HEAD LINK
LS1077/LS366A	RAISING SHAFT FOR CENTRE PIN
LS1077/LS468	RELEASE PEDAL LEVER
LS1077/LS469	FOOT PEDAL
LS1077/LS470	PIN FOR RELEASE PEDAL SPRING
LS1077/LS611	SLEEVE FOR HANDWHEEL SHAFT
LS1077/LS641	COWL FOR FREQUENCY CHANGER
LS1077/LS659A	TABLE
LS1077/LS808	BUSH FOR TABLE
LS1077/LS816	FRAME FOR PERFORATED ZINC COVER
LS1077/LS833	COVER PLATE FOR EXHAUST OPENING
LS1077/LS846/A	HEAD SLIDE
LS1077/LS853	FOOT LEVER R.H.
LS1077/LS854	FOOT LEVER L.H.
LS1077/LS857	INSPECTION COVER
LS1077/LS858	CONNECTING LINK FOR HEAD
LS1077/LS859	UPPER LEVER
LS1077/LS861	BUSH FOR CONNECTING LEVER
LS1077/LS862	BUSH FOR UPPER LEVER
LS1077/LS975	CENTRE PLATE
LS1077/LS1074	CUTTER GUARD
LS1077/LS1285	NUT FOR HEAD STOP
LS1077/LS3051	BRACKET FOR HEAD LINK
LS1077/LS3056	HANDLE FOR STOP QUADRANT
LS1077/LU6	SLIDE FOR PLUNGER BRACKET
LS1077/LU7	PLUNGER BRACKET
LS1077/LU102	VEE STRIP FOR PLUNGER SLIDE
LS1077/LU103	ADJUSTING SCREW FOR PLUNGER
LS1077/LU104	CAP FOR PLUNGER BRACKET
LS1077/LU117	BUSH FOR PLUNGER

LS1077/LU118	BUSH EXTRACTOR
LS1077/LU121	STUD FOR PLUNGER LOCK
LS1077/LU124	ROUND TAPER PLUNGER
LS1077/LU127	FILBOE FOR RATCHET LOCK
LS3077/E119	CONTACTOR DOOR
LS3077/E465	CONTACTOR BOX
LS3077/E467	CONTROL PLATE
LS1077/1A	TEE LOCKING HANDLE
LS1077/2	LOOSE COLLAR
LS1077/2A	STAR HANDWHEEL
LS1077/2B	STAR HANDWHEEL
LS1077/2C	STAR HANDWHEEL
LS1077/4D	TWO BALL HANDLE
LS1077/8A	STAR HANDWHEEL
LS1077/LD17	BRACKET SUPPORTING CUTTER GUARD
LS1077/LD65	VERTICAL POST FOR GUARD
LS1077/LD66	STOP COLLAR FOR GUARD
LS1077/10/2 $\frac{1}{2}$ /1	HANDWHEEL
LS1077/8/2 $\frac{1}{2}$ /1	HANDWHEEL
LS1077/NA24	CLIP FOR PERFORATED ZINC COVER
LS1077/NA26	SHOULDER PIN FOR CLIP
LS1077/WH413	COLLAR FOR PLUNGER FINGER PIN
LS1077/HA/3/51	SPRING FOR RELEASE PEDAL LEVER
LS1077/STD177	HANDLE

LS1077/QE3

MITRE WHEEL

LS1077/SKF08

BEARING

LS1077/QK1

RUBBER BUFFER

LS1077/RD43

FULCRUM PIN FOR STOP QUADRANT

LS1077/SDC79

BUSH

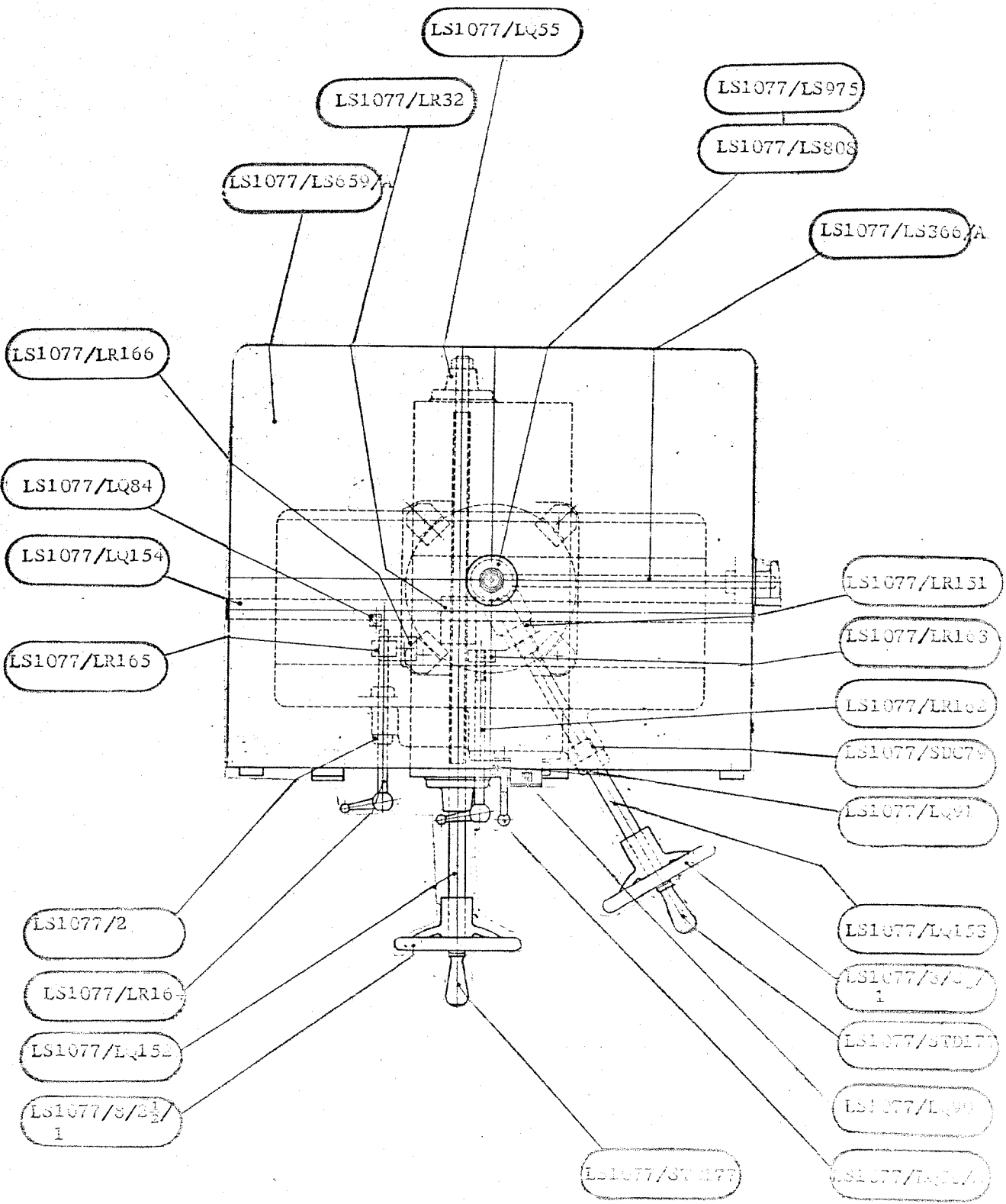

TOP VIEW OF COMPOUND TABLE

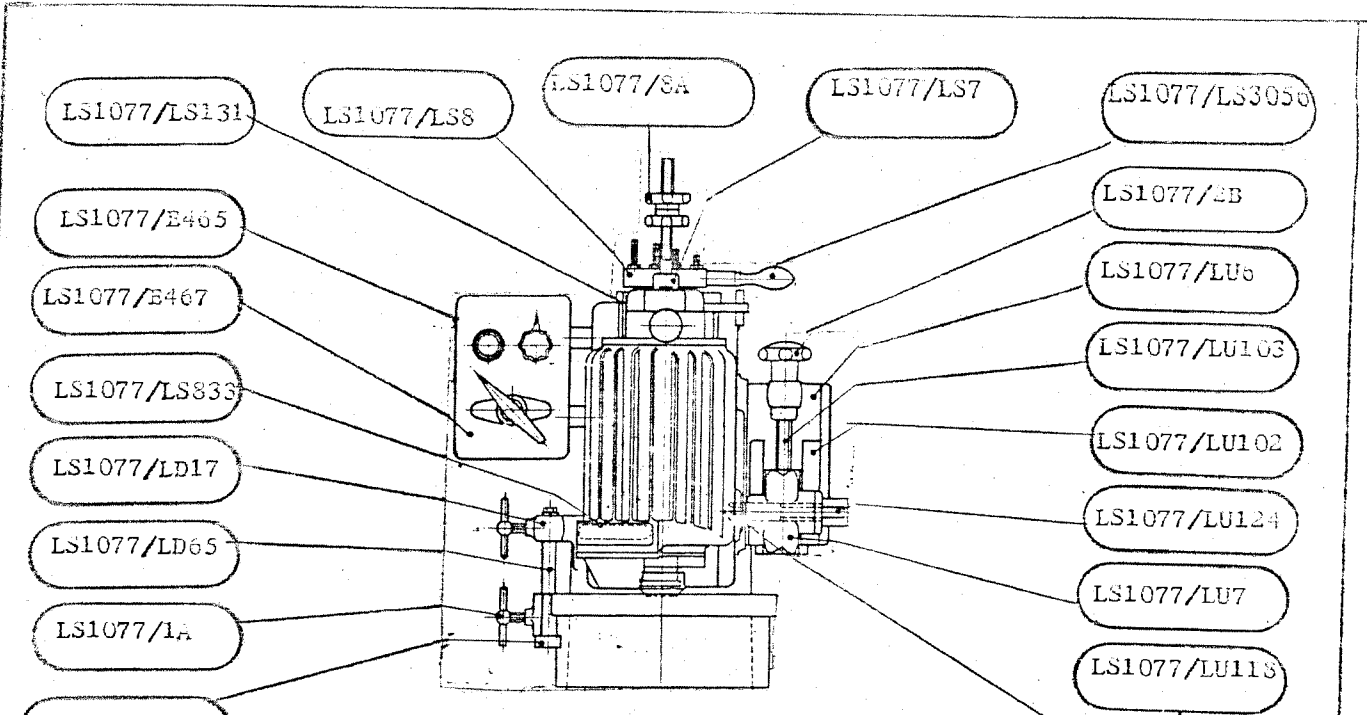

- LS1077/LS131
- LS1077/E465
- LS1077/E467
- LS1077/LS833
- LS1077/LD17
- LS1077/LD65
- LS1077/LA
- LS1077/LD66
- LS1077/LS8
- LS1077/8A
- LS1077/LS7
- LS1077/LS3050
- LS1077/EB
- LS1077/LU6
- LS1077/LU103
- LS1077/LU102
- LS1077/LU124
- LS1077/LU7
- LS1077/LU118
- LS1077/LU117

FRONT VIEW OF HEAD

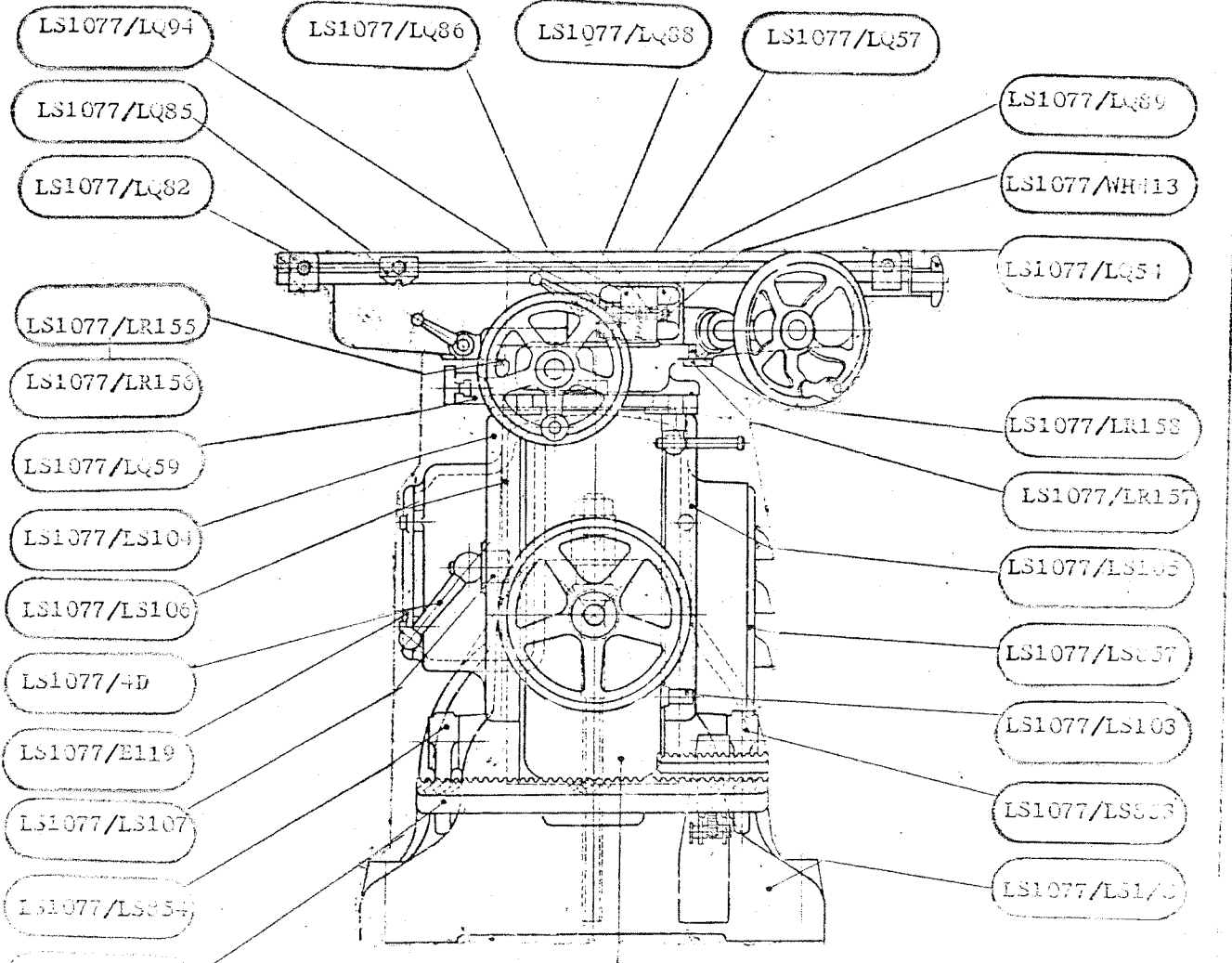

- LS1077/LQ94
- LS1077/LQ85
- LS1077/LQ82
- LS1077/LR155
- LS1077/LR156
- LS1077/LQ59
- LS1077/LS104
- LS1077/LS106
- LS1077/4D
- LS1077/E119
- LS1077/LS107
- LS1077/LS354
- LS1077/LS489
- LS1077/LQ86
- LS1077/LQ88
- LS1077/LQ57
- LS1077/LQ89
- LS1077/WH413
- LS1077/LQ51
- LS1077/LR158
- LS1077/LR157
- LS1077/LS105
- LS1077/LS357
- LS1077/LS103
- LS1077/LS358
- LS1077/LS101

FRONT VIEW OF COMP TABLE

LS1077/L 537

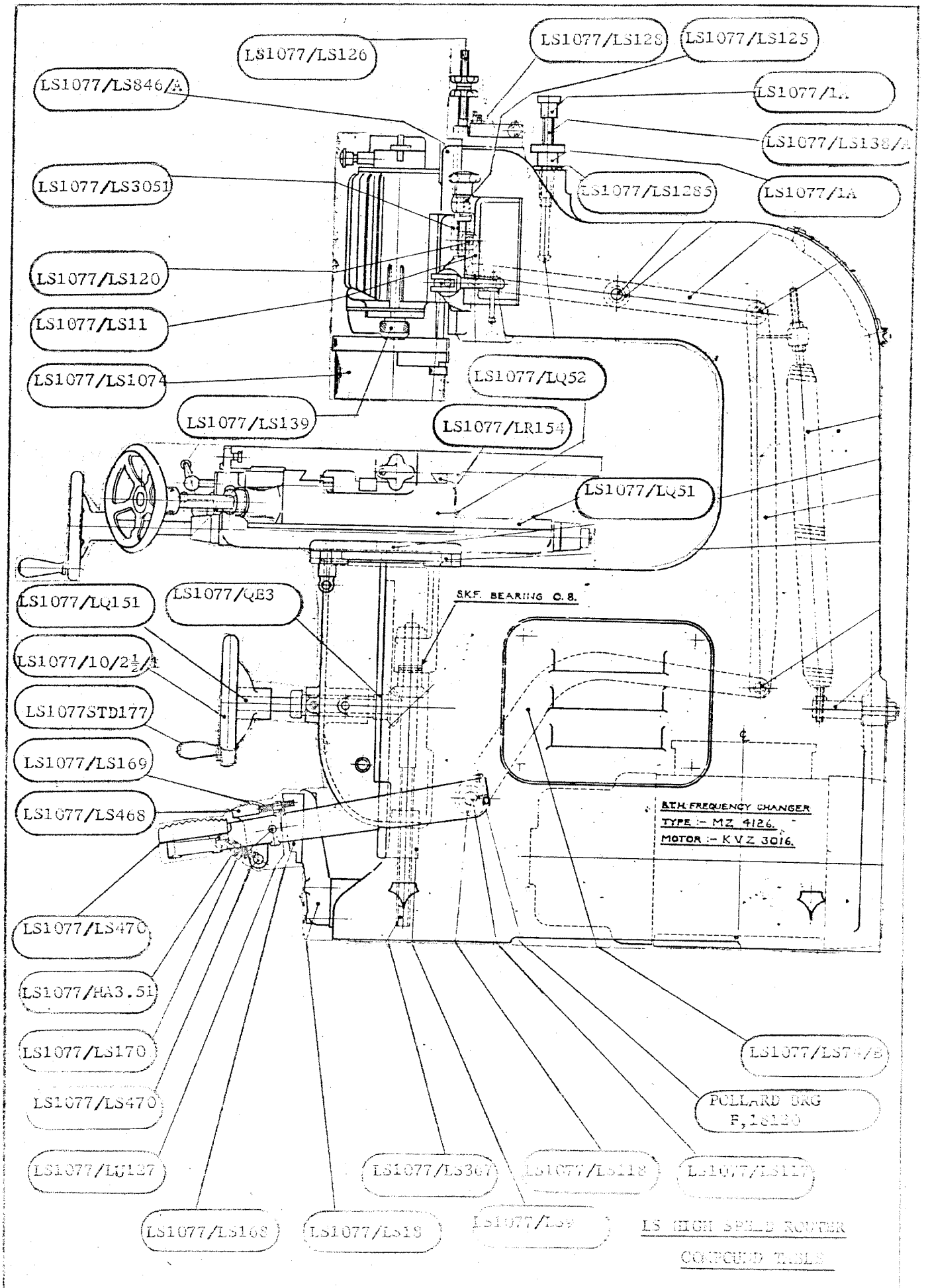

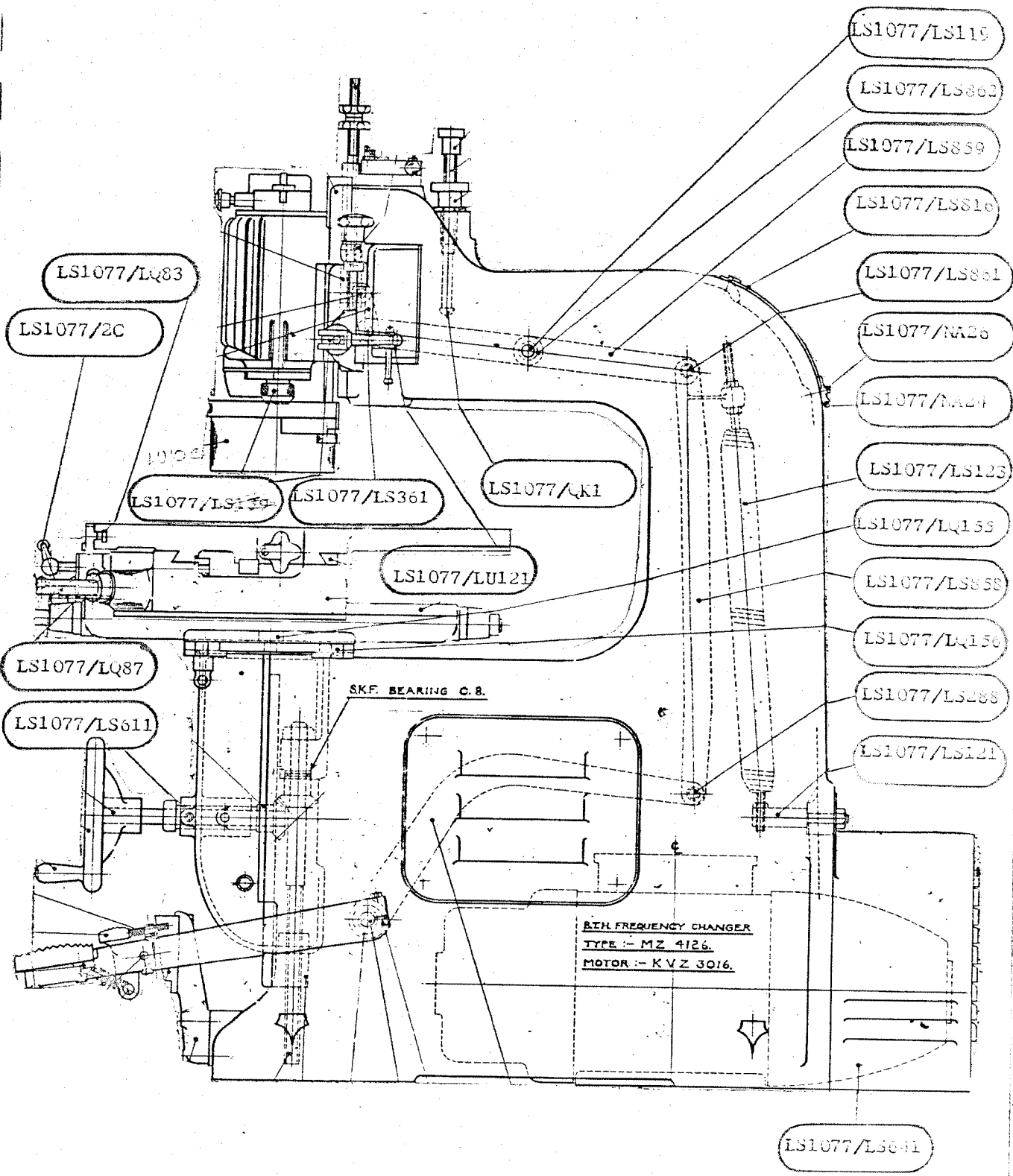

END VIEW OF MACHINE



SPARE PARTS BOOKLET

CONTENTS

1. Basic ordering requirements.
2. Sample type order.
3. List of item numbers and description of item.
4. Drawing showing item numbers.

LS Q & R TYPE

ROUTER HEAD

LS Q & R ROUTER HEAD SPARE PARTS LIST

LS884/LS82/A	STATOR FRAME WITH FINS 2 HP
LS884/LS84	BUSH FOR BOTTOM BEARING OF STATOR FRAME
LS884/LS88	BLOWER PIPE
LS884/LS139	NUT FOR CHUCK
LS884/LS223	SLEEVE OVER ROTOR
LS884/LS261	BRAKE SHOE
LS884/LS262	BRAKE PLUNGER
LS884/LS263	BRAKE LINING
LS884/LS265	BAR FOR SPINDLE LOCK
LS884/LS266	STUD FOR SPINDLE LOCK BAR
LS884/LS267	STUD FOR BRAKE HOUSING COVER
LS884/LS399	LOCKNUT FOR ROTOR SHAFT
LS884/LS415	LOWER SLEEVE FOR ROTOR SHAFT
LS884/LS443/B	BRAKE HOUSING
LS884/LS447	TOP BEARING LOCKNUT
LS884/LS448	BRAKE DRUM
LS884/LS449	TOP SLEEVE OVER BEARING
LS884/LS452	BAFFLE PLATE
LS884/LS601/A	COVER FOR BRAKE HOUSING
LS884/LS813	COVER FOR BRAKE HOUSING
LS884/LS814	BAR FOR SPINDLE LOCK
LS884/LS833	COVER PLATE FOR EXHAUST OPENING
LS884/LS863	SPRING FOR SPINDLE LOCK
LS884/LS872	TOP SPACING SLEEVE
LS884/LS874	BOTTOM END COVER
LS884/LS876/A	SPINDLE
LS884/LS877/A	SPINDLE
LS884/LS880	FELT RING FOR TOP BEARING
LS884/LS881	FELT RING FOR BOTTOM BEARING
LS884/LS882	TOP END SHIELD
LS884/LS883	TOP OIL FEED PIPE
LS884/LS3009	SPECIAL CAPNUT

LS884/LE16/A	BOTTOM END COVER FOR HEAD
LS884/LE236	TEMPLATE GUIDE HOLDER
LS884/LE451/A	BOTTOM END COVER
LS884/LE685	OIL PAD CUP FOR LE16/A
LS884/5875	TECALEMIT ANCHOR
LS884/PC2	WAKEFILED NIPPLE
LS884/QAJ62	INSTRUCTION PLATE
LS884/QAJ212	INSTRUCTION PLATE
LS884/UR245	HESS SPINDLE
LS884/1A	PIPSCREW
LS884/5	SPRING

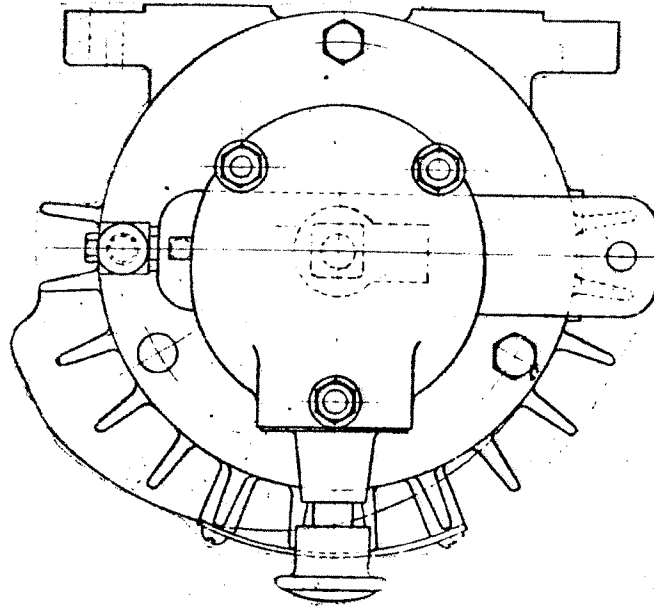

TOP VIEW OF ROUTER HEAD

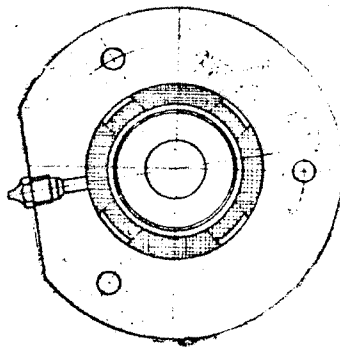

SECTIONAL VIEW SHOWING OILWICKS TRAPPED IN POSITION WITH FELT PAD

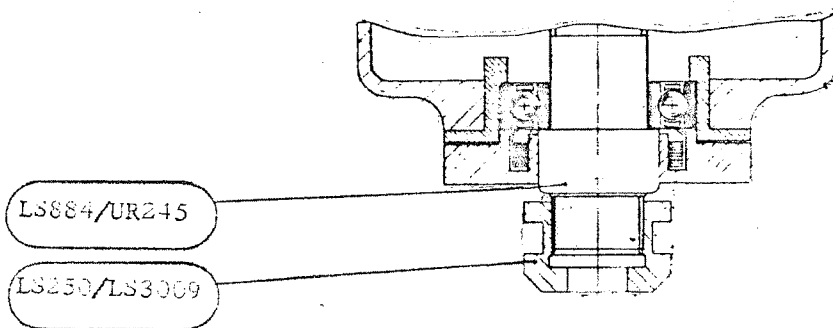

HESS TYPE SPINDLE END

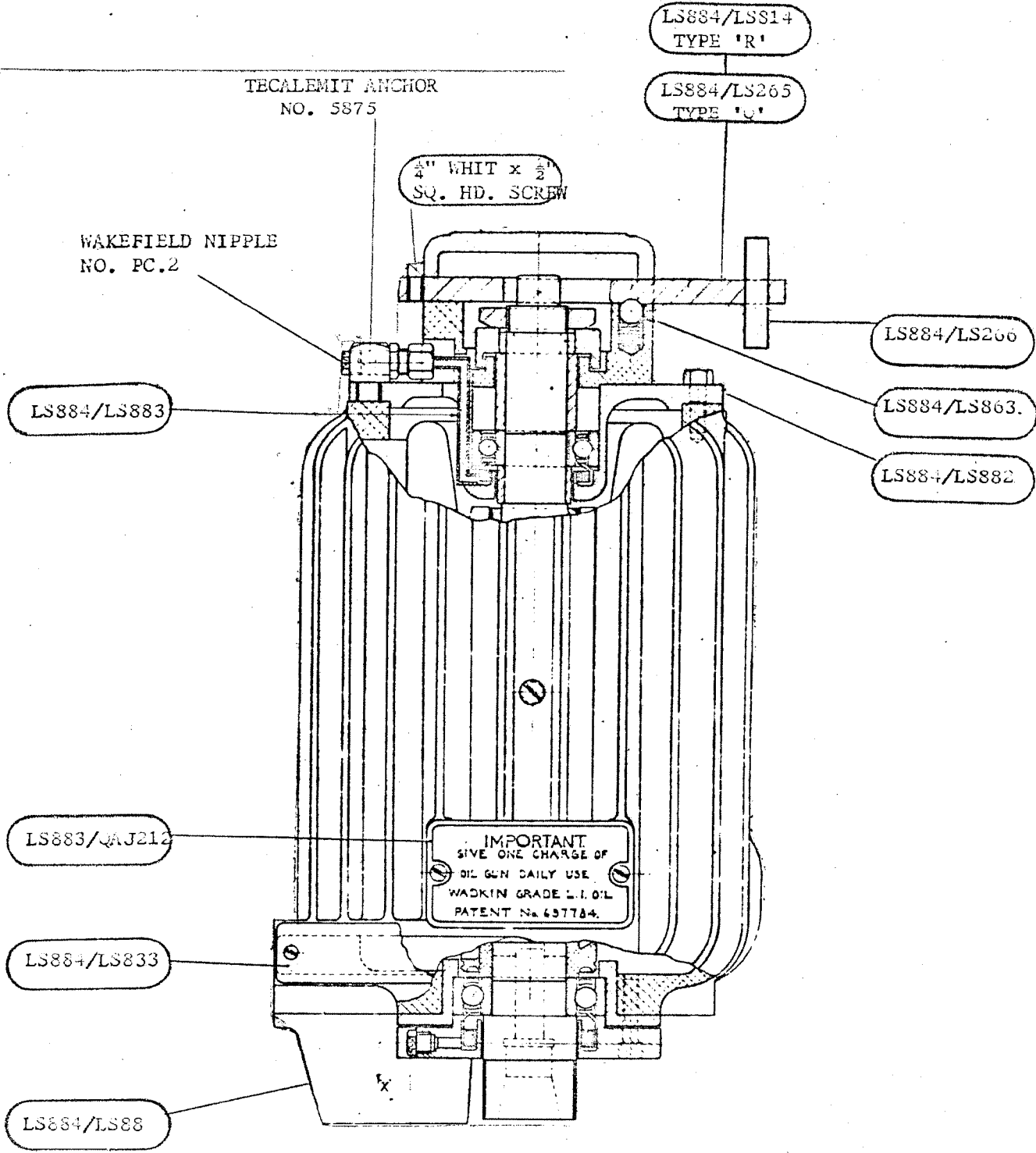

LS Q & R TYPE ROUTER HEAD

SECTION THROUGH 'Q' TYPE
HEAD SHOWING BEARING ETC.

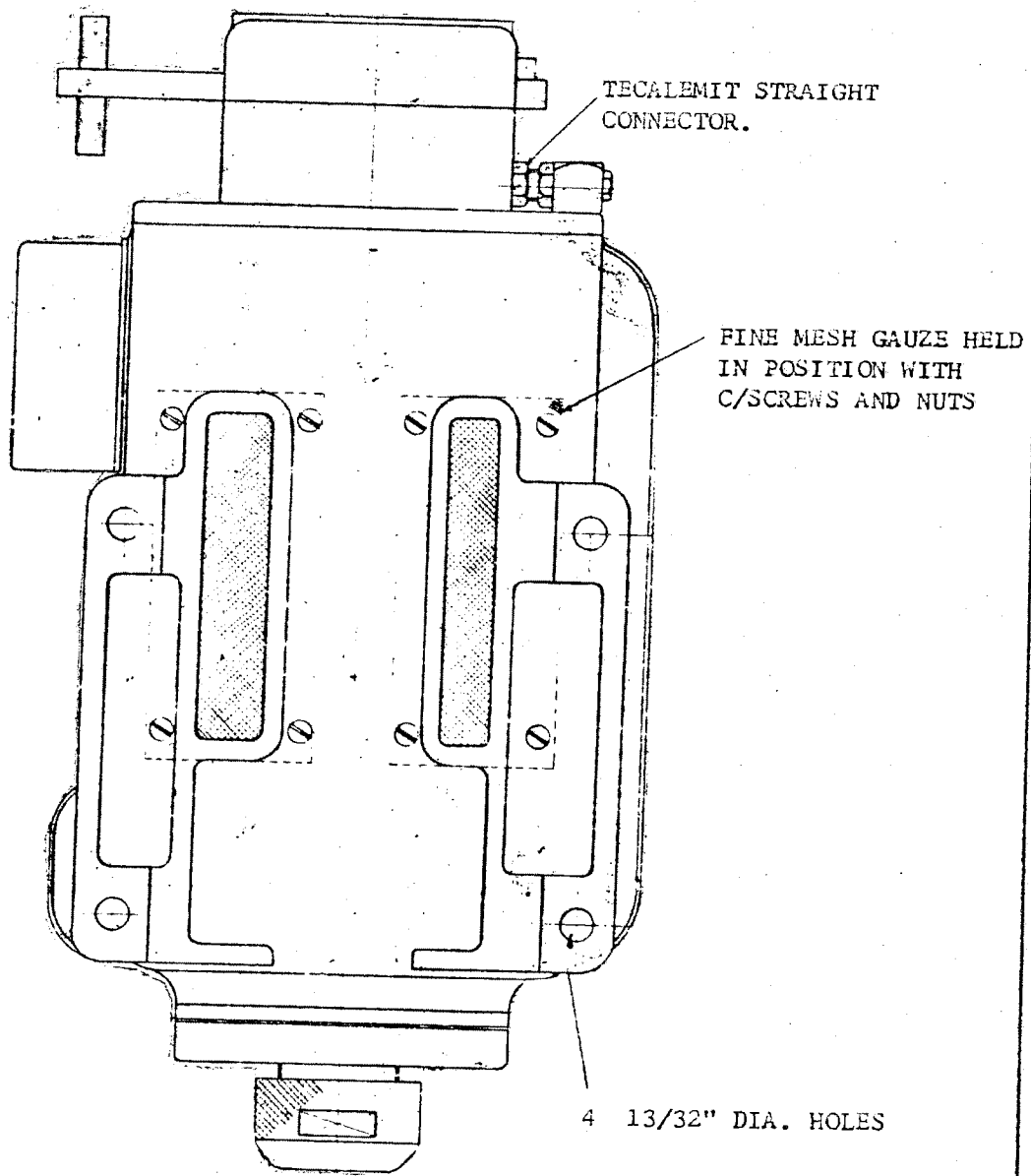

BACK VIEW OF ROUTER

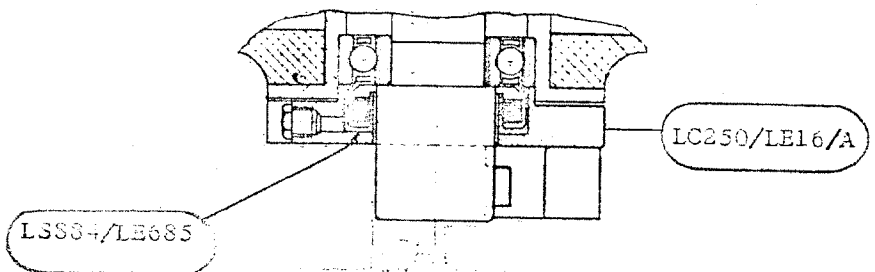

SPECIAL END ASSEMBLY TYPE 'R' HEADS.
ON EARLY RADIAL ARM MACHINES

SPECIAL END ASSEMBLY TYPE 'R' HEADS ON EARLY RADIAL ARM MACHINES